

SC

Checklist for Bidders

Enquiry #: 13432
M/s, _____

Opening Date: _____ Time: _____
Phone No: _____

Please Ensure before submitting the bid, that following information/ Documents have been submitted / providing along you bid
Check () appropriate box.

S. No.	Details of required information / documents	Yes	No
1.	Fixed Bid Bond as specified in Tender Document		
2.	Original Technical literature is enclosed, if any		
3.	Any change in your current address, Phone Fax no & Email etc intimated		
4.	Bid Validity as specified is mentioned		
5.	Delivery / Completion period has been specified.		
6.	All corrections/cutting/overwriting are signed & stamped		
7.	Sample (if necessary) is enclosed		
8.	Form- X Duly Signed & Stamped		
9.	Each & Every Page of the bidding documents shall be signed and stamped by the bidder.		
10.	Original Bid + One Copy is Submitted		

Note:

Non-availability of the above information/documents, or incomplete/incorrect statement on this checklist may result in rejection of the bid at / after the bid opening.

As per SRO296(I)/2023 dated 08th March 2023 "E-Pak Procurement Regulations, 2023" all bidders are advised to register in e-Pak Acquisition and Disposal System (EPADS).

Bidders Authorized Representative





M/s. _____

**CONSTRUCTION OF BOUNDARY WALL ENCLOSURE, CC
FLOORING & GUARD ROOM**

Supplier must be active in FBR Active Taxpayer List (ATL)

Under Single Stage Two Envelope Bidding Procedure

Tender Enquiry No. SSGC / SC / PT / 13432

SECTION - I

Invitation to Bid

Sui Southern Gas Company Limited (SSGC) intends to carry out the work related to Civil Works for Construction of Boundary Wall Enclosure, CC Flooring & Guard Room with Bathroom at TBS Bin Qasim Industrial Park, Karachi (As per Criteria/TOR/BOO) (Having Valid PEC Certificate Category C-6 or above with Subcategory CE-10) (Under Single Stage Two Envelope Bidding Procedure) (On Complete Package Basis).

The Company invites you to submit Technical Proposal and Financial Proposal in two separate sealed envelopes “**Under Single Stage Two Envelope Bidding Procedure**” i.e. Sealed Technical offer & Sealed Financial offers shall be submitted in separate envelopes. Technical offers will be opened and evaluated first. Financial offers of only technically compliant bidders will be opened on later intimated date in presence of bidder’s representative.

The priced bids shall be submitted along with FIXED Bid Bond Rs. 2,00,000 (Two Hundred Thousand Rupees Only) in the form of Pay order / Demand Draft in favor of Sui Southern Gas Company Limited. No bid shall be entertained without bid bond / earnest money.

The Company reserves the right to add, delete from or amend any part of these tender documents during the bidding period and bidders shall be informed accordingly.

Bids not conforming to the terms and conditions or a part thereof; stipulated in these tender documents may be rejected.

The Tender documents comprise the following:

Technical Proposal

Section – I	Invitation to Bid
Section – II	Instructions to Bidders (A&B) Instruction to Applicants
Section – III	Scope of Work/Special Condition of Contract/Technical Evaluation of Bid/with Forms
Section – IV	Special Conditions of Tender Document
Section – V	General Terms & Conditions



Financial Proposal

Section – VI	Tender Form
Section – VII	Bill of Quantity (BOQ)/Bid form/Estimate Cost
Section – VIII	Bid Bond Format/Performance Bond /Format of Declaration/Contract Form/Form X/Annexure I/ Form of Bid Securing Declaration
Section – IX/X	Blacklisting Mechanism/HSE Manual/SSTW-05/Drawings

Application for technical and financial proposals will be received at:

**Procurement Department,
Sui Southern Gas Company Limited,
Tender Room (Ground Floor of CRD Building)
SSGC House, Sir Shah Suleman Road,
Block-14, Gulshan-e-Iqbal,
Karachi.
Tel # 99021238, 99021279.**

On or before **11-10-2024** at **1530 hrs.** The bids will be publicly opened at **1600** hours on same day at the above address, in the presence of bidders and / or their authorized agents who may wish to attend. All bids are to be delivered on or before closing time after which all bids submitted after the time prescribed shall not be entertained and will be returned without being opened. In case bid is sent through courier, the same shall be delivered at least half an hour before scheduled opening time.

Tenders shall be enclosed in plain sealed envelope marked as:

“STRICTLY CONFIDENTIAL”

CONSTRUCTION OF BOUNDARY WALL ENCLOSURE, CC FLOORING & GUARD ROOM

Enquiry # SSGC/SC/13432

For **General Manager (Procurement)**

Note: Tender document is also available online on SSGC website for view only. Bidder is eligible to participate in bidding process only after purchasing the tender documents from Tender Room SSGC Head Office as per the procedure mentioned in the Press Publication / SSGC website. It is mandatory for bidders to attach original Token Slip in front of the Sealed Envelope (issued at the time of Purchasing) as an evidence that supplier has purchased the Tender documents. Further, any Corrigendum/Clarifications/Addendums/Extensions issued to be notified to only those bidders who have purchased Tender documents.

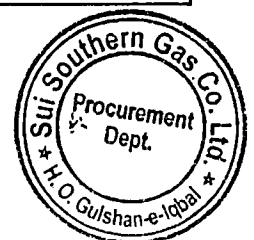

TECHNICAL
PROPOSAL



SECTION - II

INSTRUCTIONS TO BIDDERS

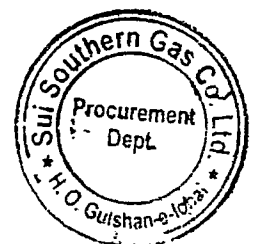

SECTION - II

Instructions to Bidders (A)

1. All rates quoted in the prescribed SOR / BOQ shall be firm, irrevocable and not subject to change or escalation on any account what so ever. No modification, alteration or deletion in the bid will be accepted after the bid opening time.
2. Sealed Bids shall be received at Company's Head Office, ST-4/E, Block - 14, Sir Shah Sulaiman Road, Gulshan-e-Iqbal, Karachi, up to specified time & date and will be opened publicly at specified time & date, in the presence of Bidders or their authorized representative who choose to attend. In case the bid opening date falls on a holiday or due to some unavoidable circumstances, it is not possible to open on scheduled date, it will be opened on next working day at the same time.
3. All original bid documents accompanied with the bid bond shall be submitted by the Bidder in the envelope provided with tender documents. The sealed Bids must be submitted at the address stated above in person or by courier or by any other means but it shall be the Bidder's responsibility to ensure that Bids so submitted are delivered to the above address before the specified Bid opening date and time. The Company shall not be held responsible in any way for late receipt of Bids or their confidentiality. Bids received after the Bid closing time shall not be considered, and will be returned to the Bidder unopened.
4. In Case of single stage two envelop bidding system (if mentioned in press advertisement & Tender document), sealed technical offer & sealed bid shall be submitted in separate envelopes (bid bond will be enclosed with "Financial" bid unless and until specified separately in tender terms). "Technical" and "Financial" is to be mentioned on the top of the envelop. Technical offers will be opened and evaluated first. Financial offer of only technically complaint bidders will be opened at a later intimated date in presence of bidder's representative. Financial offers of technically non-complaint bidders will be returned un-opened along with their bid bond.
5. The Bid should be signed by a person having the authority for this purpose. In case of a bid submitted by a corporate entity, the same shall bear its seal and be duly signed by its secretary.
6. Bids shall be submitted strictly in accordance with the requirements of the Tender Documents and as per specifications.
7. Bid shall remain valid for acceptance for a period of (120) days from the date of public opening of the bids.
8. The Company shall not reimburse any expenses incurred in preparation of Bids.
9. The Bid and all subsequent correspondence shall be in the English language.
10. Payment for the Contracted Work / Services will be made in Pakistani Rupees only. The rates quoted by the Bidder shall therefore, be in Pakistani Rupees.
11. In case of any queries / clarification with regard to this Tender, the same may be forwarded to Procurement Department upto 5 days before the bid opening date, thereafter the request will not be considered.
12. The Company reserves the right to reject any or all Bids without assigning any reason and cancel the bidding process. Company also reserves the right to accept the whole or a part of Bid and does not bind itself to accept the lowest or any particular Bid.
13. In case of any conflict between the Special Terms & Conditions and elsewhere in the tender documents the Special Term & Conditions, will supersede & prevail.
14. Each and every page of the bid documents being submitted by the bidders shall be signed and stamped failing which the bid may be liable for rejection.
15. All documentary evidence required for evaluation of bid should be submitted along with the bid in absence of any documentary evidence no marks will be awarded in accordance to the evaluation criteria.
16. In order to maintain cordial business relation and as per ethical business approach, please provide the justification in case of your non participation on our Fax # 99231583 & Email. mnite@ssgc.com.pk.
17. Conditional Bid will not be accepted and liable to be rejected.
18. The quoted unit price and corresponding total amount shall be inclusive of all duties and Taxes and excluding provincial Sales Tax as per provincial laws.
19. Sealed bids shall be mailed/submitted/dropped in tender box placed at Tender Room, CRD Building, SSGC Head Office. Bids are to be delivered on or before closing time after which bid will not be entertained. If bid is sent through courier, the same shall be delivered at least half an hour before scheduled opening time.
20. Price given in the Bid Form/BOQ is firm which shall take into account all relevant factors including discount, if any. Discount / escalation given separately at the time of bid opening will not be considered.
21. The bidders are required to fill form SS'W-05 (if deemed required) and submit with the bid.

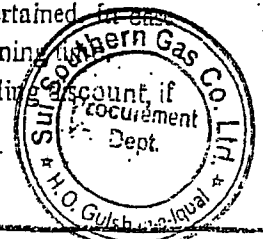

SECTION-B**INSTRUCTIONS TO BIDDERS (B)****1. Escalation**

It may be clearly understood that this tender does not contain a price variation clause and, therefore, all unit prices quoted shall be firm and irrevocable and shall not be subject to escalation on any account, whatsoever.

2. Bid Instructions

The bid shall be prepared in accordance with the following instructions:

2.1 Examination

Bidders shall visit/inspect the Work sites and shall fully acquaint themselves with the nature and requirements of Work, form and nature of sites, access to sites, availability of materials, weather, law and order and local conditions etc. before submitting their bids. **Submission of the bid shall be prima facie evidence that the Bidders have fulfilled this requirement.**

2.2 Clarifications

Each Bidder shall be deemed to have satisfied himself before submitting as to the correctness and sufficiency of its tender/offer and the rates quoted, which rates shall, cover all its obligations under the Contract and all matters and things necessary for proper completion and maintenance of the Work. The Bidder may submit questions/queries regarding these documents to the Company in writing within a period extending up to 10 (ten) days after issuance of the tender enquiry. Replies shall be issued to all Bidders in writing and will be on record as addenda to the ensuing Contract. The Company will not be responsible for verbal clarifications. The bid submission time will however not be extended on this account.

2.3 Validity

Bids shall remain valid for acceptance for a period of **One Hundred Fifty (150) days** from the date of bid opening. If the last date falls on a holiday, the validity will be extended to the first Company working day thereafter.

2.4 Cost of Preparation of Bid

Bidders will not be reimbursed for costs of any kind, whatsoever, incurred by them in connection with the preparation and the submission of their bids.

2.5 Bill of Quantities and Rates

The quantities specified in the Bill of Quantities (BOQ) are estimated and are intended to serve only as a guide to the Bidders. Payments shall be made on the basis of actual work quantum as measured. No claims shall be entertained on account of increase or decrease in the scope of work. The Bidders shall ensure that their bids are not front-end loaded, which may lead to rejection of their bids. The bidder shall quote the rates on Section-VIII, Bill of Quantities of the tender document. Rates quoted on other form will be rejected.

2.6 Sub-Contracting

The Bidder shall include a list of works which he intends to sub-let to sub-contractors. Sub-contractors proposed by the Bidder are subject to Company's approval.

2.7 Bid Documents

Bidders shall note that the tender documents including plans, drawing and specifications, furnished for tendering purposes are not to be used for any purpose other than bidding on this specific job and shall not be reproduced without the written permission of the Company. All such documents issued for tendering shall be returned with the bid duly stamped.

2.8 Organization Chart

An Organization chart proposed for the conduct of the Work shall be submitted with the bid.

* H. J. A. Q. I. V. C. E. S. P. K.



The chart shall clearly show permanent members of the Bidders supervisory staff that the Bidder proposes to deploy on the work sites for the performance of the Work.

2.9 List of Equipment

The Bidder shall submit with the bid, a complete list of equipment proposed to be used in carrying out the Work including make and type of all such equipment.

2.10 Time Schedule

The Bidder shall submit with his bid, a detailed work programme in the form of a bar chart showing planned schedule of various activities required to complete the entire work (as per Scope of Work) within the stipulated completion period by deploying adequate manpower.

2.11 Additions, Deletions and Amendments

The Company reserves the right to add, to delete from and/or amend the work defined in Scope of Work/BOQ as deemed necessary before or after the execution of the contract. All such additions deletions and amendments shall only be authorized in writing by the Company's representative.

2.12 Signing Authority

Bidders shall return all tender documents (including drawings) duly signed on all pages by an authorized representative of the Bidder and shall also carry official stamp of the Bidder's firm.

2.13 Postal Address

The Bidder shall give below office telephone, telex and fax numbers including complete postal address at which correspondence may be sent and all notices may be legally served in connection with his bid and/or ensuing contract with the successful Bidder.

Name of Firm : _____

Telephone Nos : _____

Telex No : _____

Fax No : _____

Address : _____

2.14 Disqualification/Rejection of Bids

Failure to comply with any instruction in the tender documents would render the bid liable to disqualification and rejection.

2.15 Unit Work Rates Bids

The unit rates quoted by the Bidder shall be workable. The Bidder shall be required to furnish a complete rate analysis of any work item as considered necessary. If the bid of the successful bidder is seriously unbalanced in relation to SSGC estimate of the cost of work to be performed under the contract, SSGC may require the bidder to produce detail price analysis for any or all items of the Bill-of Quantities to demonstrate the internal consistency of those prices with the construction method and schedule proposed. After evaluation of price analysis, SSGC may require that the amount of Performance Bond set forth in the tender document be increased at the expense of successful bidder to a level sufficient to protect SSGC against any Financial Loss in the event of default of the successful bidder under the contract.

Handwritten signature and initials: S. Khan, P&C

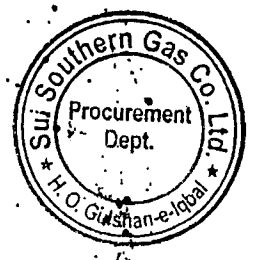
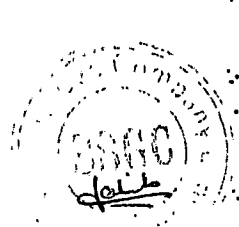

2.16 Check List

Bidder shall, inter alia, ensure the following before submitting the bid:

- All pages of the bid including drawings have been signed and stamped.
- Bid Bond/Earnest Money for the specified amount has been enclosed.
- List of equipment and detailed work schedule required under Clause 2.9 & 2.10 of Section II, is enclosed.
- Postal address, telephone, telex and fax Nos. (If available have been given in Clause 2.13 of Section II).
- Total amount of Bid has been mentioned in 9c, Section VII, Tender Form.
- Duly authorized representative has signed (along with witness) at the end of Tender Form, Section VII.

*M. J. Hameed
CEO
SSGC*



SECTION - I A

INSTRUCTIONS TO APPLICANTS

1. Sui Southern Gas Company Limited (SSGC) intends to technically qualifying contractors for the Construction of Boundary Wall Enclosure, CC Flooring & Guard Room with Bathroom at TBS Bin Qasim Industrial Park, Karachi (Single Stage Two Envelope Bidding Procedure) who have valid Pakistan Engineering Council registration in Category- C-6 Sub category C-10 under Single Stage Two (02) Envelope Bidding Procedure.
2. Technical Qualification Application(s) (FORM-I: LETTER OF APPLICATION) shall be submitted along with forms duly filled/completed in a sealed envelope as per requirement and sent by registered post / courier or delivered in person at the address mentioned in the subject form.
3. All the information shall be filled-in/submitted strictly as per "Forms" enclosed. If necessary, additional photocopies of the "Forms" may be made. Each page of each form should be clearly marked on the top right corner as follows:
Page 1 of Form I
Page 2 of Form I.....; etc.
4. Some forms will require attachments (documentary evidence, etc.). Such attachments should be clearly marked as follows:-
Attachment 1 of Form I
Attachment 2 of Form I.....; etc.
5. In case the attachments where required are not enclosed with the application, no credit/points will be given for that particular item.
6. Each sheet shall be duly stamped & signed by the applicant(s) or a person or persons duly authorized to sign on behalf of the applicant(s) otherwise not considered for evaluation.
7. All documents submitted by the applicants shall be treated as confidential and will not be returned. Only financial bids of non-technically complaint bidder will be returned after due process.
8. Documents received after the due date will not be considered and will be returned un-attended. The name and mailing address of the applicants shall also be mentioned on the envelopes so that the application can be returned unopened.
9. SSGC will only inform the successful/qualified applicants of the result of their application. SSGC reserves the right to reject or accept any application and to annul the technical qualification process and reject all applications, without thereby incurring any liability to the affected applicants or any obligation to inform the applicants of the grounds for the action of SSGC.
10. The technical qualification Questionnaire contains forms as follows:

Form-I:	Letter to Application
Form-II:	General Information
Form-III:	Details of Completed Similar Type of Projects/Works During Last Five (05) Years
Form-IV:	Details of Permanent Key Staff with the Firm/Contractor
Form-V:	Details of Relevant Equipment/Tools/Machinery owned by the Firm
Form-VI:	Registration/Office facilities
Form-VII:	Financial Stability

All the information shall be submitted strictly in accordance with the above formats/forms. Company brochures, etc. could be forwarded as supplementary but will not be entertained in lieu of the prescribed formats.

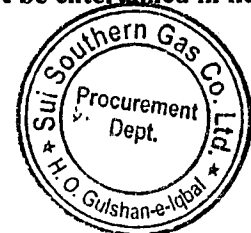

** K. J. Haidy
E. S. S. P. C.*

EVALUATION OF APPLICATION FOR TECHNICAL QUALIFICATION

1. The firm/contractor must submit a valid PEC registration for the year 2024-25 in C-6 Sub category C-10.
2. SSGC may request additional information, or documents in support of information submitted by the firm/contractor.
3. The decision of SSGC to accept or reject any application for technical qualification will be final.
4. The firm desiring to be technically qualified must have suitable machinery & equipment and qualified experienced manpower to handle the subject project.
5. Application for technical qualification of each applicant will be compared with a predetermined set of values and Minimum Qualifying marks = 65% (Overall).

** 19. Approved
SSGC
PAC*

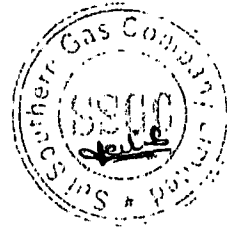

SECTION-III - A

SCOPE OF WORK

Sui Southern Gas Company Limited (SSGC) intends to undertake Construction of Boundary Wall Enclosure, CC Flooring & Guard Room with Bathroom at TBS Bin Qasim Industrial Park, Karachi. The contractor/firm shall supply adequate manpower as well as sufficient machinery and material required for the execution of the Work. The contractor/firm shall ensure safe and proper execution of the work and shall complete the work within the completion period. The detailed scope of work is also attached here.

All the below specified material or any other item that is not mention here but used for construction/modification shall be of first / prime quality (as per specifications described in Bill of Quantities), inferior or No. 2 quality of any material shall be rejected by the Company's representative. The Contractor shall remove such rejected material immediately from site as and when instructed by the Company's representative. Additionally, samples of following material shall be submitted for approval by Company's representative prior to execution of work;

"Make" of following Item / Materials shall be as specified hereunder:

• Cement (OP / SR)	Local made only.
• Block	Machine made to be approved by the Company.
• Fine Aggregates	(Bholari or equivalent) Approved by company.
• Course Aggregates	First Class (To be approved by the Company).
• Stone Soling	First Class (To be approved by the Company).
• Steel Reinforcement	Amerali or Equivalent (To be approved by Company).
• Paint	Gobi, ICI or equivalent (To be approved by Company).
• Aluminum Doors/windows	Lucky, Kurudson or equivalent (To be approved by Company).
• UPVC Pipe	Steelex, Pak Arab or equivalent (Approved by Company).
• Fibre Tank	Master or Equivalent (To be approved by Company).
• Wash Basin & WC	ACL, Durr or Equivalent (To be approved by Company).
• Washroom Fixtures	Master or Equivalent (To be approved by Company).
• Steel Doors	Local made to be approved by the Company.
• Water Pump	Javeed, General or Equivalent (To be approved by Company).
• SBR	Sika, Vertex or equivalent to be approved by company
• PVC Electric Conduits	Galco/Shavyl or equivalent approved by the Company
• Channel Patti	ADAMJEE or equivalent approved by the Company
• Electrical Cables	Pakistan Cables, AGE, Pioneer or equivalent approved by the Company
• Switch Sockets	CLIPSAL Australia or equivalent to be approved by the Company
• Distribution Board	Al Moin, Prem or equivalent to be approved by the Company
• Circuit Breakers	Terasaki (Japan), Hauger (France) to be approve by the Company
• Light & Lighting Fixtures	Osaka, Factor or equivalent to be approved by the Company

A.S.
M. J. J.
SSGC
P&C

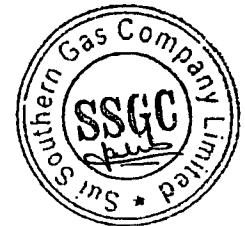

SECTION-III - B**SCOPE OF WORK****DESCRIPTION OF WORK****A. Boundary Wall:****1) Excavation:**

Providing all labour and material for excavation & Backfill in all kind of soil for foundations of columns, Plinth Beams or anywhere as required below ground level up to any depth including rock/hard soil and backfilling with the excavated material, dewatering shoring and disposing off all surplus materials outside the site of work to an appropriate location for complete construction of Boundary wall per drawing BOQ, Specifications & Site requirements and as directed by engineer incharge.

This item also include cost of removing surplus soil from site to designated dumping site.

2) Stone Soling:

Providing all labour and material for placing and compacting stone soling using 3" thick & downsize, compacted with mechanical compactor under foundations including grouting with Crush stones & coarse sand, Complete in all respect and as per drawing BOQ, Specifications & Site requirements and as directed by engineer incharge.

3) DPC:

Providing all material, tools and labour for providing and applying 2" thick DPC (Cement Sand with padlo mix) to be laid over plinth beam complete in all respect as per drawing, BOQ, specification, site requirements and as directed by the Engineer Incharge. This item also includes the cost of apply asphalt premier to the foundation, below plinth columns and plinth beams.

4) Lean 1:4:8

Providing all labour, tools, material, machines & equipment for mixing, forming, placing, compacting, curing and removing formwork in concrete (1:4:8) using S.R Cement in Foundations, or where required, complete in all respect and as per drawing BOQ, Specifications & Site requirements and as directed by engineer incharge.

5) SITU 1:3:6

Providing all labour, tools, material, machines & equipment for mixing, forming, placing, compacting, curing and removing formwork in concrete (1:3:6) using S.R Cement below plinth beam or where required upto required level, complete in all respect and as per drawing BOQ, Specifications & Site requirements and as directed by engineer incharge.

6) Concrete 1:2:4

Providing all labour & material for mixing, placing, forming, compacting with mechanical vibrator, curing, and removing formwork in Machine mix 1:2:4 concrete (1 part Cement, 2 Parts Fine Sand, 4 parts Crush Stones) using S.R/O.P Cement in foundations, plinth Beams and Columns & Coping of boundary wall or where required with steel gurmala finish and approved quality material. Complete in all respects and as per drawing BOQ, Specifications & Site requirements and as directed by engineer incharge.

Note:

- SR.Cement should be used in all structures upto Plinth beams
- This item also include the cost of thermo pole in column connections joint

7) Steel Reinforcement:

Providing all labour & Material, machine and equipment for providing, cutting, bending, placing

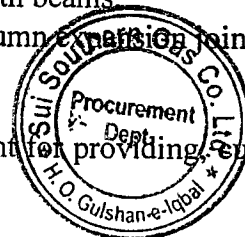

Handwritten signature and initials: Haini, E. E. C. M., P. C.

and tying steel reinforcement of 60 KSI yield strength deformed bars of specified make including the cost of binding wire, wastage, over rolling, chairs and spacers in footing, columns, Beams complete in all respects and as per drawing BOQ, Specifications & Site requirements and as directed by engineer in charge.

8) Block Masonry:

Providing all labour material, tools and machinery and equipment for providing and laying Block Masonry 8" thick or otherwise mentioned below & above plinth level up to required height in boundary wall, Plinth protection set in 1:4 cement sand mortar (using SR cement below plinth and OP cement above plinth). Complete in all respects and as per drawing BOQ, Specifications & Site requirements and as directed by engineer incharge.

9) Plaster:

Providing all labour, tools, Materials and equipment for making, applying and curing 3/4" thick Plaster in 1:4 cement-sand mortar to all exposed surfaces of boundary walls, Plinth Beam and columns including vertical /horizontal chamfering splays, jambs, recesses, mouldings, making rounded coves as shown in details, edges, rebates, grooves, expanded metal lath at junctions between structural members & masonry Complete in all respects and as per drawing BOQ, Specifications & Site requirements and as directed by engineer incharge.

10) Weather Shield Paint:

Providing all labour, tools, materials & equipment for applying and painting 3 coats of Weather Shield on all side the wall of specified make and shade including preparation of surface to be painted after applying single coat of Primer Complete in all respects and as per drawing BOQ, Specifications & Site requirements and as directed by engineer incharge.

11) Main Gate: (16'x10')

Providing all labour, tools, materials and equipment for providing and installing Double leaf open able hinged type MS gate having insignia of SSGC, wicket gate, 3/4" floor rail with wheels having three coats of oil paint over single coat of red oxide Complete in all respects and as per drawing BOQ, Specifications & Site requirements and as directed by engineer incharge.

12) Barbed & Razor wire:

Providing all labour material and tools for fabrication and fixing of Y- shape angle iron frame size 2"x2"x1/4" thick of required size, making slot for four (04) strands barbed wire 2.64mm on each arm including two (02) coats of enamel paint over anti-rust primer coat including Galvanized / Pre coated barbed wire with four (04) stands on each arm of Y-shape angle iron frame and galvanized / pre coated Razor wire 3ft dia having 22mm wide blade, 36mm a part (26 Nos spirals in 35 Rft bundle) tired with the barbed wire with galvanized binding wire on each side of Y-shape angle iron frame. Complete in all respects and as per drawing BOQ, Specifications & Site requirements and as directed by engineer incharge.

13) Plinth Protection

Providing all labour material and tools for construction of plinth protection on Road Side Boundary Wall as per drawing comprises of 8" thick Block Masonry with plaster on exposed surface, 6" thick stone soling over 4" thick 1:4:8 over 2" thick 1:2:4 complete in all respects per site requirement, Drawing, BOQ and Specification and as directed by engineer incharge.

B. Earth Filling

1) Earth Filling:

Providing all materials for Cutting, Filling, placing, dressing, levelling, and compacting Earth material obtained from approved outside sources for preparation of Flooring or where required. Earth filling shall be carried out in layers not exceeding 1' thickness or as per site requirement as directed by engineer incharge, making & maintaining lines, grades, side slopes, cross slopes and



Handwritten signature and initials: * 14. H. S. P. 22/2/2022

crowns, breaking clods, watering and consolidation to 95% of the maximum dry density, using mechanical roller. This item also include the cost of all the levelling dressing of existing soil.

C. CC Flooring

Providing all material labour tool and equipment for laying CC Flooring as per following specifications

1) 6" thick Stone Soling:

Providing all labour and material for placing and compacting stone soling using 3" & downsize, 6" thick stone soling compacted with mechanical compactor under floor including grouting with coarse sand & Crush stone, Complete in all respect and as per drawing BOQ, Specifications & Site requirements and as directed by engineer incharge.

2) 3" thick Lean 1:4:8:

Providing all labour and material for mixing, forming, placing, compacting, curing 3" thick concrete (1:4:8) using S.R Cement in Floor, complete in all respect and as per drawing BOQ, Specifications & Site requirements and as directed by engineer incharge.

3) 3" thick 1:2:4:

Providing all materials, mixing, placing, laying, compacting and curing for C.C. Floor comprising of 3" thick cement concrete 1:2:4 (1 part cement, 2 parts fine clean sand, 4 parts graded crushed stone of 3/4" & down) using S.R. cement (trowel finish) laid in 6'-0" X 5'-0" panels using 5mm X 25mm glass strip, proper levels gradient (slope), compacting, curing, etc. Complete in all respect and as per drawing BOQ, Specifications & Site requirements and as directed by engineer incharge.

D. Guard Room With Washroom

1) Excavation:

Providing all labor and material for excavation & Backfill in all kind of soil for foundations of columns, Plinth Beams or anywhere as required below ground level up to any depth including rock/hard soil and backfilling with the excavated material, dewatering shoring and disposing off all surplus materials outside the site of work to an appropriate location for complete construction of Guard Room as per drawing BOQ, Specifications & Site requirements and as directed by engineer incharge.

This item also include cost of removing surplus soil from construction site to dumping site.

2) Stone Soling:

Providing all labour and material for providing, placing and compacting stone soling using 3" thick & downsize, compacted with mechanical compactor under foundations including grouting with Crush stones & coarse sand, Complete in all respect and as per drawing BOQ, Specifications & Site requirements and as directed by engineer incharge.

3) DPC:

Providing all material, tools and labour for providing and applying 2" thick DPC (Cement Sand with padlo mix) to be laid over plinth beam complete in all respect as per drawing, BOQ, specification, site requirements and as directed by the Engineer Incharge.

4) Lean 1:4:8:

Providing all labour, tools, material, machines & equipment for mixing, forming, placing, compacting, curing and removing formwork in concrete (1:4:8) using S.R Cement in Foundations, or where required, complete in all respect and as per drawing BOQ, Specifications & Site requirements and as directed by engineer incharge.

5) SITU 1:3:6

Providing all labour, tools, material, machines & equipment for mixing, forming, placing

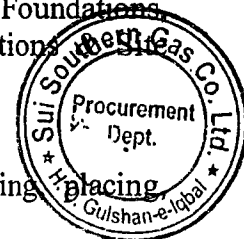

compacting, curing and removing formwork in concrete (1:3:6) using S.R Cement below plinth beam or where required upto required level, complete in all respect and as per drawing BOQ, Specifications & Site requirements and as directed by engineer incharge.

6) Concrete 1:2:4

Providing all labour & material for mixing, placing, forming, compacting with mechanical vibrator, curing, and removing formwork in Machine mix 1:2:4 concrete (1 part Cement, 2 Parts Fine Sand, 4 parts Crush Stones) using S.R/O.P Cement in foundations, Beams and Columns & Slabs or where required with steel gurmala finish and approved quality material. Complete in all respects and as per drawing BOQ, Specifications & Site requirements and as directed by engineer incharge.

Note: SR Cement should be used in all structures upto Plinth beams.

7) Steel Reinforcement:

Providing all labour & Material, machine and equipment for providing, cutting, bending, placing and tying steel reinforcement of 60 KSI yield strength deformed bars of specified make including the cost of binding wire, wastage, over rolling, chairs and spacers in footing, columns, Beams complete in all respects and as per drawing BOQ, Specifications & Site requirements and as directed by engineer in charge.

8) Block Masonry:

Providing all labour material, tools and machinery and equipment for providing and laying Block Masonry 8" thick or otherwise specified below & above plinth level up to required height in walls, or where required set in 1:4 cement sand mortar (using SR cement below plinth and OP cement above plinth). Complete in all respects and as per drawing BOQ, Specifications & Site requirements and as directed by engineer incharge.

9) Plaster:

Providing all labour, tools, Materials and equipment for making, applying and curing 3/4" thick Plaster in 1:4 cement-sand mortar to all surfaces of exposed walls, Beams, Slab including vertical /horizontal chamfering splays, jambs, recesses, moldings, making rounded coves as shown in details, edges, rebates, grooves, expanded metal lath at junctions between structural members & masonry Complete in all respects and as per drawing BOQ, Specifications & Site requirements and as directed by engineer incharge.

10) Roof Screeding with Water Proofing

Providing and laying min 2" thick Roof Screeding in 1:2:4 cement concrete over roof slab in proper slope, finish, curing complete in all respect and as directed by engineer incharge. This item includes all the cost of 02 coats of Water Proofing Chemical (SBR Sika Bond or equivalent approved by company) in cement complete in all respect as per drawing BOQ, Specifications & Site requirements and as directed by engineer incharge.

11) CC Flooring

Providing all material labour tool and equipment for laying CC Flooring in Guard Room & Washroom as per following specifications & method mentioned above in "C" part of this description.

12) Weather Shield / Water Matt Paint:

Providing all labour, tools, materials & equipment for applying and painting 3 coats of Weather Shield on all side the outer wall and water matt inside walls and ceiling of specified make and shade after applying single coat of Primer including preparation of surface to be painted Complete in all respects and as per drawing BOQ, Specifications & Site requirements and as directed by engineer incharge.

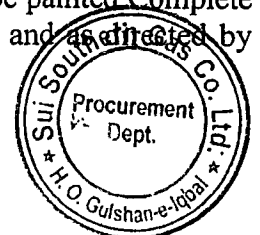

*-y-
Sui Southern Gas Company Limited
Procurement Dept.

13) MS Door (3' x7')

Providing all labour, tools, materials and equipment for providing and installing single leaf open able hinged type MS door (Door side angles 1"x1"x1/4" & 20 Gauge Sheet) with MS angle with 16 Gauge GI Chokat frame with hinges and proper locking arrangement on both sides including 3 coats of Oil Paint along over single coat of red oxide Complete in all respects and as per drawing BOQ, Specifications & Site requirements and as directed by engineer incharge.

14) Aluminium Window / Ventilator with grill

Providing all labour and material for making and fixing Aluminum windows / Ventilator of required size using 4" wide bronze high class anodized 1.2 mm box section having 03 nos. Sliding panels fully glazed of specified make along with the fiber Mesh Panel using 5mm thick local best quality approved tinted glass including all hardware, Stoppers, sealers, fittings and locking arrangements Complete in all respects and as per drawing BOQ, Specifications & Site requirements and as directed by engineer incharge.

Note: This item also includes the cost of providing and fixing MS grill including 3 coats of Oil Paint along over single coat of red oxide on same windows & Ventilator as per drawing attached.

15) Water Lines:

Providing and laying UPVC pipeline 1/2" Dia for cold water supply (Concealed) to each water outlet from OHWT of specified make for 01 No bathrooms. This item included all UPVC specials tees, bends, elbows, plugs, brass elbows, reducers cutting chiselling holes etc. in walls or floor and other required material for completion of work in all respects and as directed by the engineer.

16) Sewer Pipe:

Providing and laying UPVC pipeline of 4" dia for WC, Floor Traps (Inside Washroom) and Main sewer line with bell or spigot socket or collars joints including the cost of lowering the pipes in correct alignment and grade, jointing with 1:2 CC mortar, spun or hemp yarn etc. 1:2:4 cement concrete pad at junctions/joints, cutting of floor and wall, all connections with existing lines and any other work required to complete the work in all respect and as directed by engineer.

This item also include the cost of 3 to 4 Block Masonry chamber (2'x2') with cover as per site requirement.

Sewer Line must be connected to the Main Sewerage line outside the plot area

17) Indian Water Closet:

Supply and fixing Indian type coupled glazed ceramic water closet (01 No.) of approved shade with 13 liters low level glazed ceramic / plastic flushing cistern with siphoned flushing mechanism of overflow system and "S" or "P" trap. All exposed hardware is to be chromium plated brass complete in all respects and as approved by the engineer.

18) Floor Trap:

Providing and fixing in position floor trap (02 Nos) with stainless steel grating of specified make and connecting to waste pipe, complete as shown on the drawings including making holes in floors, walls and concrete and reinstating the surface on completion of work as specified and directed by the Engineer.

19) Fibre Glass OHWT:

Providing all material, tools, equipment and labor for providing and installing 100 gallon capacity Fiber Glass overhead Water Tank (01 No.) including required pipe fittings complete in all respect and as directed by the Engineer Incharge.

20) Wash Basin:

Providing and fixing glazed Ceramic approved colour Glazed wash basin (01 No) of (18" or 24" as per requirement) of specified make of approved shade with pedestal complete with 12mm dia.

* 3/4
Handy
CSCW
Pal

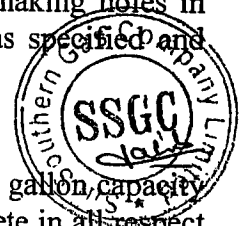
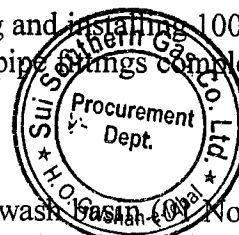

of specified make pillar cock and bottle trap wall type with pipe including connection to waste pipe, cast iron brackets, one rubber plug, chromium plated brass chain, tee stop cock complete in all respect as specified.

21) Bathroom Fixture:

Providing and fixing in position following Bathroom Accessories of approved make of approved colour comprising of following: (This item includes all the necessary hardware required for fixing).

- i 01 No. Wash Basin Mixer (Metal)
- ii 01 No. Bib Cock with Muslim Shower (Metal)
- iii 03 No. Tee Cock / Bib Cock (Metal)
- iv 01 No. Soap Dish.
- v 01 No. Looking Glass. (2ft x 2ft)

22) Electrical Works:

Providing all tools, labour & material for electrical work having the following jobs to be performed, complete in all respect as per drawing, specifications and instructions of the Engineer Incharge. (All the wiring shall be carried out in appropriate size PVC conduit / channel Patti exposed /concealed as per site requirements)

- a) Supply & installation of DB (size 12" x 06") made of 16 SWG sheet with 10 Amp DP circuit breaker (01no.), 20 Amp SP circuit breaker (02 nos.)
- b) Circuit wiring with 2 x 2.5 sqmm. + 1 x 1.5 sqmm ECC (01 no.) along with 05 gang switch board (02 nos.), including wiring from switch board to switch board with 2 x 2.5 sqmm + 1 x 1.5 sqmm ECC copper PVC cable.
- c) Wiring for light & fan point with 2 x 1.5 sqmm + 1 x 1.5 sqmm (07 nos.)
- d) Wiring for 3 pin switch socket with 2 x 2.5 sqmm + 1 x 2.5 sqmm along with back box and face plate (01 no.)
- e) LED lights 12 Watts (06 nos.)
- f) Ceiling fan with 56" dia with fan dimmer (01 no.)

*14. Shairly
Cleary
PSC.

E. Under Ground Water Tank

Providing all labour material tool & equipment for construction of RCC underground water tank (06 ft x 06 ft x 8ft) (Internal dimension) as per below mentioned activities complete in all respects as per drawing, site requirements and as directed by engineer incharge.

1) Excavation:

Providing all labour and material for excavation in all kind of soil for foundations of UGWT below ground level up to any depth including rock/hard soil and backfilling with the excavated material, dewatering shoring and disposing off all surplus materials outside the site of work to an appropriate location outside company premises as per drawing BOQ, Specifications & Site requirements and as directed by engineer incharge.

2) Stone Soling:

Providing all labour tools, equipment and material for providing, placing and compacting stone soling using 3" & downsize, compacted with mechanical compactor under foundations including grouting with coarse sand, Complete in all respect and as per drawing BOQ, Specifications & Site requirements and as directed by engineer incharge.

3) Lean 1:4:8:

Providing all tools, labour, equipment and material for providing, mixing, forming, placing, compacting, curing and removing formwork in concrete (1:4:8) using S R Cement in Foundations complete in all respect and as per drawing BOQ, Specifications and as directed by engineer incharge.

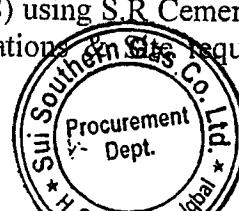

4) Steel Reinforcement:

Providing all labour, tool, equipment & material for cutting, bending, placing and tying steel reinforcement of 60 KSI yield strength deformed bars of specified make including the cost of binding wire, wastage, over rolling, chairs and spacers in footing, Walls & Slabs complete in all respects and as per drawing BOQ, Specifications & Site requirements and as directed by engineer in charge.

5) Concrete 1:2:4:

Providing all labour & material, tools and equipment for providing, mixing, placing, forming, compacting with mechanical vibrator, curing, and removing formwork in Machine mix 1:2:4 concrete (1 part Cement, 2 Parts Fine Sand, 4 parts Crush Stones) using S.R Cement in all member of UGWT including slabs, walls and stairs with steel gurmala finish and approved quality aggregate. Complete in all respects and as per drawing BOQ, Specifications & Site requirements and as directed by engineer incharge.

Note:

This item also include the cost of water stopper (Sika Water bar V-20 L SH or equivalent) having min width of 20cm and nominal thickness of 2mm - 4 mm on construction joints of outer walls of UGWT

6) Plaster:

Providing all labours tools and equipment & material for making, applying and curing 3/4" thick plaster in 1:4 cement-sand mortar to all internal surfaces of walls and Exposed external surfaces of UGWT including vertical /horizontal chamfering splays, jambs, recesses, mouldings, making rounded coves as shown in details, edges, rebates, grooves, expanded metal lath at junctions between structural members and concrete joints Complete in all respects and as per drawing BOQ, Specifications & Site requirements and as directed by engineer incharge.

Note: This item includes the cost of providing and applying approved Water proofing chemical (SBR) on inner sides of tank after finishing of plaster.

7) Water Proofing:

Providing all material, labour, equipment and tools for providing and applying 02 Coats of 10/20 Grade hot bitumen @ 30lbs per 100 sft upto NGL on external surfaces of tank Complete in all respects and as per drawing BOQ, Specifications & Site requirements and as directed by engineer incharge.

8) CI Covers 18"x18" (Heavy Duty):

Providing all material, labour and tools for providing and installing Cast Iron Heavy Duty Cover with frame (18"x18") including 02 Coats of Enamel Paint over single coat of red oxide complete in all respects and as per drawing BOQ, Specifications & Site requirements and as directed by engineer in charge.

9) Monkey Ladder:

Providing all material, labour and tools for providing and installing monkey ladder having 3/4" dia GI pipe with 12" pipe length & and 12" space between two pipes complete in all respects and as per drawing BOQ, Specifications & Site requirements and as directed by engineer in charge.

10) J Vent UPVC Pipe (2" Dia 1ft high)

Providing all material, labour and tools for providing and installing J Vent UPVC Pipe having 2" Dia and 1ft high complete in all respects and as per drawing BOQ, Specifications & Site requirements and as directed by engineer in charge.

11) Water Line:

Providing all material tool equipment for Providing, Laying (underground and Overhead both) &

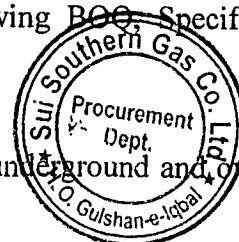

Handwritten signature and initials:
 *K. J. Hain
 C. S. S. P. 7C

commissioning UPVC (1") waterline from UGWT motor to OHWT & from utility connection outside boundary wall to UGWT. This item includes the cost of all the material (elbow, socket joint, Brass elbow, adhesive solution etc.), hardware, tool & equipment use for proper functioning including cost of foot valve required

12) Centrifugal Pump:

Providing all labour material & tools for supply and installation of 01 No. 0.5 HP centrifugal mono block water pump for pumping water from UGWT to OHWT including all accessories required for connection complete in all respect and as per site requirement, BOQ Specifications and as directed by engineer incharge.

This item includes all the cost of installation including Electrical Wiring connection with breaker and proper shed for pump."

NOTE:

Any item, material or job mentioned here and not visible / present in drawing shall be considered as part of this tender and contractor must execute that job without any additional payment and likewise, Any item, material or job not mentioned here and visible / present in drawing shall be considered as part of this tender and contractor must execute that job without any additional payment.

**14. S. H. Khan
Asst. Engg.
P&C*



SECTION-III

SPECIAL CONDITIONS OF CONTRACT

1. Representative of the Company

The Representative of the Company for the purpose of this contract would be
Mr Ghulam Ali Mahar DGM-I (P&C)

2. Signing of Agreement

Formal signing of agreement shall be completed as soon as possible. However, the firm shall mobilize/commence work after issuance of Letter to Proceed. Formal agreement/contract would be made on stamp paper of value at the rate of Rs. 0.35 per hundred rupees of the value of contract. The stamp duty would be borne by the engineering firm.

3. Completion Period

The entire work shall be completed within **Six (06) months** from the issuance of Letter to proceed; which in case of work exigencies could be issued prior to signing of formal agreement.

4. Liquidated Damages

The rate of liquidated damages shall be **0.1% percent** of the delayed / remaining work for each day of delay and shall be capped to a maximum of **Ten (10%) percent** of the final contract value.

5. Certificate of Substantial Completion of Work

As soon as the Work shall have been substantially completed and corrected and shall have satisfactorily passed any test that may be prescribed by the Contract, the Contractor shall give the Company a notice of completion calling on the Company to inspect the works, and after inspection the Company shall grant a certificate of substantial completion and period of maintenance of the works shall commence from the date of such certificate provided that the Company may give such a certificate with respect to any part of the works before the completion of the whole of the works and shall upon the written application of the Contractor give such certificate with respect to any substantial part of the Work which has been completed to the satisfaction of the Company and occupied or used by the Company and when any such certificate is given in respect of a part of works, such part shall be considered as completed and period of guarantee and maintenance of such part shall commence from the date of such certificate. However, it shall be a condition precedent to the issue of certificate of "Substantial Completion" that the Contractor shall indemnify the Company against any failure by the Contractor to have carried out and completed the works in accordance with the Contract and shall warrant that the works are completed in every respect and conform to the Contract.

6. Final Completion Certificate

The Contract shall not be considered as completed until a final certificate have been issued by the Company's stating that the works have been completed corrected and maintained to satisfaction provided the Contractor has rectified all the defects mentioned in the "Punch list of Defects" to the entire satisfaction of the Company's representative. The final certificate shall be given by the Company after expiration of the period of maintenance or if different period of maintenance shall become applicable to different parts of the works the expiration of the last of such period and full effect shall be given to this clause notwithstanding any previous entry on the works or the taking possession working or using thereof or any part thereof by the Company. The retention money of the Contractor shall be refunded after satisfactory completion of maintenance period and after issuance of final completion certificate.

Handwritten signature and initials
K.M. J. Hanjra
CEC
P&C

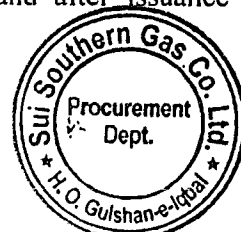

7. Monthly Deduction

Monthly deduction of **Rs.50, 000** per month shall be made in case Contractor/firm fails to deploy agreed / specified full time PEC Registered Civil Engineer.

8. Performance Bond

The performance bond shall be in an amount equal to **Five (05%) percent** of the bid value / contract value and it shall be submitted within **10 days** after issuance of the Letter of Intent before signing of the Agreement/Contract within the stipulated time. The performance bond shall be released after the satisfactory completion of the work and issuance of substantial completion certificate.

9. Security Arrangement at Site

The firm/contractor shall be responsible to arrange all security and safety measures for staff and equipment required during undertaking the detailed engineering survey work & geotechnical investigation.

10. Maintenance Period

The maintenance period will be **Six (06) Months** after the issuance of Substantial Completion Certificate by the Company.

11. Retention Money

The retention money shall be equal to **Five (05%) percent** of the certified value of work which would be released after the maintenance period and rectification of punch list defects, to the satisfaction of the Company.

12. Mode of Payment

The payment shall be made as per following schedule on completion of work as per Drawing & BOQ and Scope of work:

Construction of Boundary Wall:

- 30% Payment of Contract / Quoted value of Boundary wall on completion of work upto Plinth level of complete / Total Boundary Wall.
- 30% Payment of Contract / Quoted value of Boundary wall on completion of work upto Block Masonry of complete / Total Boundary Wall. upto required height mention in drawing.
- 40% Payment of Contract / Quoted value of Boundary wall on completion of all remaining works of Boundary wall completed in all respect.

Earth Filling:

- 100% Payment of Contract / Quoted value of Earth Filling on 100% completion of Earth filling (executed Quantity).

CC Flooring:

- 100% Payment of Contract / Quoted value of CC Flooring on 100% completion of CC Flooring (executed Quantity).

Guard Room with Washroom:

- 40% Payment of Contract / Quoted value of Guard Room with washroom on completion of work upto roof pouring including Block Masonry.
- 60% Payment of Contract / Quoted value of Guard Room with washroom on 100% completion of all remaining works of Guard Room with Washroom completed in all respect.

Underground Water Tank:

- 100% Payment of Contract / Quoted value of Underground water tank on 100% completion of all work mentioned in scope work and drawing of Underground Water Tank.

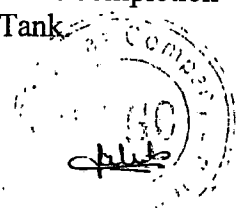
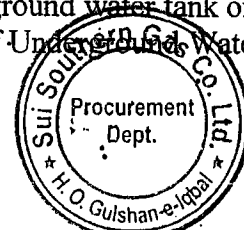

13. Disqualification / Blacklisting

The Company reserves the right to implement the clauses as per rules defined in PPRA rules Nos. 18 & 19. The decision in this regard will be firm, final and binding on all bidders.

14. Survey Equipment

The contractor/firm shall provide all the required survey equipment at site. The survey instrument / equipment shall be in good condition and shall be available at site for use by the Company.

15. Quality of Cement

Cement shall be procured from the approved local factories only complying with BS 4027. Imported cement shall not be used under any circumstances.

16. Fine Aggregate / Coarse Aggregates (Complying with BS 882)

i) Approved quality of sand shall be used as fine aggregates.

ii) Well graded crush stone (3/4" and down) of approved quality shall be used as aggregates.

17. Water and Electricity

Water & electricity requirement for all purposes shall be arranged by the firm/ contractor. Only sweet water complying with ASTM-D 596 shall be used for construction works.

18. Quality of Material, Workmanship and Tests

All material and workmanship shall be of respective kinds described in the contract (drawings, sketches/BOQ/specifications/scope of works, etc.) and in accordance with the Company instructions and shall be subjected to tests from time to time as the Company may direct. **There will be no compromise on the quality of workmanship or material.** The firm/contractor shall provide such assistance, instruments, machines, labor and materials as are required for examining, measuring and testing any work and the quality, weight or quantity of any material used. The Contractor/firm shall supply samples of materials before incorporation in the work for testing and/or approval as may be selected and required by the Company. All samples shall be supplied by the Contractor/firm at his own cost and the cost of carrying out all such tests shall also be borne by the Contractor/firm.

In order to ensure quality of construction the Company (besides carrying out other tests as required under the contract) may carry out chemical tests to find out the ratio of cement and aggregate for the mortar or concrete used in the work. This shall also be at Firm/ Contractor's cost.

Contractor shall be responsible to follow all the SOPs regarding Quality and HSE and will be sole responsible to fill the quality inspection plan and follow.

19. Damage to Property and Persons

The firm/contractor shall, except if and so far as the Contract provides otherwise, indemnify and keep indemnified the Company against all losses and claims for injuries or damage to any persons or property whatsoever arise out of or in connection with or in consequence of the construction and maintenance of the works and against all claims demands, proceedings, damages, costs, charges and expenses whatsoever in respect of or in relation hereto.

20. Site Visit

The bidders are advised to visit and examine the Site of Works and its surroundings and obtain for themselves on their own responsibility all information that may be necessary to get clarity regarding scope of work/ BOQ for preparing the bid and entering into a contract for construction of the subject works. All cost in this respect shall be at the bidder's own expense.

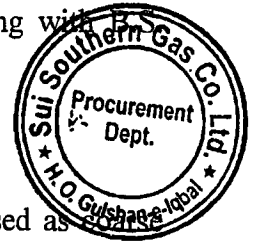

Handwritten signature and initials.

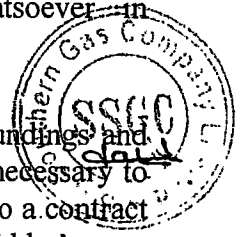

21. Health Safety Environment (HSE)

The firm/Contractor will follow the Health, Safety & Environmental conditions as mentioned in Section-X "HSE Manual". The Firm/Contractor shall also deploy a full time qualified and experience safety manager for strict compliance to company's HSE policy. To ensure the safety of workers, utmost care shall be taken while cementing broken glass and installing razor wires onto the boundary walls.

22. Issuance of Revise Letter to Proceed (LTP)

If the site will not be handed over to contractor/firm due to site clearance after issuance of Letter to Proceed (LTP), then revise LTP will be issued to the contractor/firm.

23. Provision of Mobile Phone Facility

Contractor will provide mobile phone with internet (Mobil data) facility to his supervisor at site in order to maintain 24 hours contact with Engineer-Incharge during the execution course of the project. And ensure that site supervisor timely provide pictorial progress of each activity to the Engineer Incharge.

24. Daily Progress Report

Contractor is responsible to maintain Daily Progress log at site and record all the details of daily executive work activities, issues related to site, detail of manpower and work done. Contractor will also submit weekly progress report along with the signed copies of Daily progress log to the Engineer Incharge.

NOTE:

- In case of any conflict between Special Conditions & General Conditions of the contract, the Special Conditions of the contract will govern.

Handwritten signature and initials: "S. Malik" and "C.E.O." with "P.C." below.

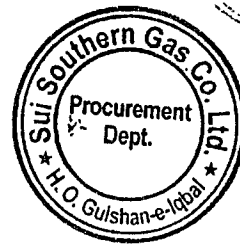

SECTION - I-B

Technical Qualification of Construction Firms / Contractors

**Construction of Boundary Wall Enclosure, CC Flooring & Guard Room with Bathroom at
TBS Bin Qasim Industrial Park, Karachi**

Tender Ref No. CIV-P&D-P&C 2K2446

SECTION - I-B

Mandatory requirements:

- Registration with PEC for category C-6 Sub Category CE-10
- Registration with Sindh Revenue Board (SRB)
- Banker's Confidential Certificate (direct from Bank)/Bank Account Statement (Last Three Year)
- Income Tax Assessment Order or Income Tax Clearance Certificate (Last Three Years)
- Office Facility in Karachi and affidavit that firm will operate from Karachi Office for this project.

Evaluation Criteria

Sno	CRITERION	OVERALL (Maximum Marks)
1	Firm's Experience	40
2	Permanent Staff	20
3	Equipment & Tools Owned / Rented by the Firm	10
4	Office Facilities	05
5	Financial Stability	25
Total Numbers		100

For the purpose of quantitative evaluation, the above five criteria have been further sub-divided as under:

	CRITERION	OVERALL (Max Marks)
1	Firm's Experience	40
	Relevant Experience of Firms with Similar Works/Projects of Last 05 Years:	
i)	10 marks for each work more than Rs. 10 million. Max 2 Projects	20
ii)	04 marks for each work more than Rs. 07 million. Max 3 Projects	12
iii)	02 marks for each work more than Rs. 04 million. Max 4 Projects	08

	CRITERION	OVERALL (Max Marks)
2	Permanent Staff:	20
i)	Civil Engineer (PEC Professional Engineer) (05 Marks Each)	05
ii)	Civil Site Engineer (PEC Registered Engineer) (03 Marks Each)	03
iii)	Civil Planning Engineer (PEC Registered Engineer) (03 Marks Each)	03
iv)	Site Supervisor (Min DAE Civil) (02 Marks Each)	04
v)	Site Supervisor (Min DAE Electrical / Electronics) (02 Marks Each)	02
vi)	Surveyor (Min DAE Civil) (01 Marks Each)	01
vii)	Accountants (01 Marks Each)	01
viii)	Computer Operator/Clerk Staff (01 Marks Each)	01

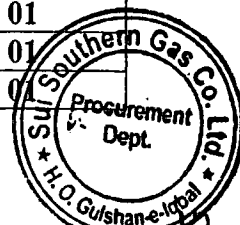

	CRITERION	OVERALL (Max Marks)
3	Equipment & Tools Owned / Rented by the Firm	10
i)	Plate Compactor (02 marks each)	02
ii)	Shuttering (2500 Sft) (03 marks each)	03
iii)	Mixer Machine (02 marks each)	02
iv)	Dewatering Pump (01 marks each)	01
v)	Generator (5KWA) (01 marks each)	01
vi)	Concrete Vibrator (01 marks each)	01

	CRITERION	OVERALL (Max Marks)
4	Registration / Office Facilities	05
i)	Office Facility in Karachi (1.5 mark each)	1.5
ii)	Computers with Primavera P6 & Microsoft Project (1.5 mark each)	1.5
iii)	Landline Telephone Facility & Internet Facility (01 mark each)	01
iv)	Email Facility (01 mark each)	01

	CRITERION	OVERALL (Max Marks)
5	Financial Stability	25
5.1	Annual Turnover for Last Three Years (Each Year)	
i)	Annual Turnover above PKR 12 Million	10
ii)	Annual Turnover above PKR 10 Million	7.5
iii)	Annual Turnover above PKR 08 Million	05
iv)	Annual Turnover above PKR 06 Million	2.5
5.2	Cash in Hand	
i)	Cash in Hand above PKR 10 Million	15
ii)	Cash in Hand above PKR 07 Million	7.5
iii)	Cash in Hand above PKR 04 Million	05
iv)	Cash in Hand above PKR 01 Million	2.5

Note:

- * Minimum Qualifying marks = 65
- Documentary evidence against each field of marking criteria may be verifiable without which marks will not be awarded.
- CVs/Resumes and PEC certificate of Engineer must be provided else no marks will be awarded.
- Surveyor must be at least DAE from any Technical Board.
- Contractor must provide affidavit that all rented / owned equipment and tools will be readily available at site as per instruction of engineer incharge

* H. A. Memon
C.E.C. / P&C

10/08/08
10/08/08



FORM-I:**LETTER OF APPLICATION**

Registered Business Name: _____

Registered Business Address: _____

Telephone: _____

Fax: _____

General Manager (Procurement)
Procurement Department,
Sui Southern Gas Company Limited,
Sir Shah Suleman Road,
Gulshan-e-Iqbal
Karachi-75300

Sui Southern Gas Company Limited
Construction of Boundary Wall Enclosure, CC Flooring & Guard Room with Bathroom
at TBS Bin Qasim Industrial Park, Karachi

Tender Ref No: CIV-P&D-P&C 2K2446

1. We hereby apply to be qualified with Sui Southern Gas Company Limited; as Engineering Firms/Contractors for execution of the above-mentioned work.
2. We authorize SSGC or its authorized representative to conduct any investigation to verify the statements, documents and information's submitted and to clarify the financial and technical aspects of this application from any person, bank, department, agency or firm.
3. The names and positions of contact persons who may be contacted for further information's, if required, are as follows:

- a) _____
- b) _____
- c) _____

**4. f*
Shahid
25/05/07

4. We declare that;

(An affidavit on Judicial / Stamp Paper of Rs. 50/- will be submitted giving the followings)

- i) The statements made and the information provided in the application are complete, true and correct in every respect.
- ii) This firm has never been black listed by any Government department, Semi government Authority or Private Company or Corporation and not involved in litigation/arbitration with any client. (In case of any involvement in litigation/ arbitration, details should be furnished)

Respectfully,
 (Authorized representative of applicant)

Date : _____

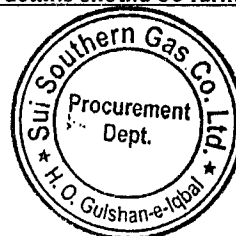

**FORM-II:
GENERAL INFORMATION**

Company Name : _____

1. Head Office Address: _____

Telephone No. _____

Fax No. _____

E-mail: _____

2. Karachi Office Address: _____

Telephone No. _____

Fax No. _____

E-mail: _____

3. Year incorporated: _____

Note: Documentary evidence (where required) is mandatory requirement and to be submitted with the bid else no marks will be awarded.

- Attach copy of certificate of registration and ownership / Rental Agreement
- State whether office premises used solely by applicant. If shared give names of other firms.

Handwritten signature and initials

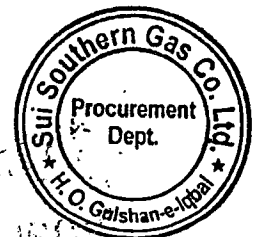

Handwritten signature

FORM-III:

DETAILS OF COMPLETED SIMILAR TYPE OF PROJECTS/WORKS DURING LAST FIVE (05) YEARS

Name of Work : _____

Scope & Details of Work : _____

Total Value of Project : _____

Value of work being executed _____

Name of Client : _____

Address of Client : _____

Telephone of Client : _____

Date of Award of Work : _____

Start Date : _____

Scheduled Completion Date : _____

Actual Completion Date: _____

Note:

- All the information provided shall be supported with documentary evidence otherwise no credit/ points will be given. Required attachments (documentary evidence, etc.) should be clearly marked as Attachment 1 to Page of Form-III or Attachment 2 to Page ... of Form-III
- Please fill one form for each work/project

Handwritten signature and initials



FORM-IV:

DETAILS OF PERMANENT KEY STAFF WITH THE FIRM/CONTRACTOR

Name	Designation	Educational Qualification	Years of Experience	Date of Appointment	Attended Training with year	Driving License No (If Required)

Note: Resume (CV) of each of the above to be submitted, and should include registration numbers (and documents) with PEC etc. No Points will be awarded if Resume not attached for individual.

**H. J. Naveed
CEO
PEC*



FORM-V:

DETAILS OF RELEVANT EQUIPMENT/ MACHINERY / TOOLS OWNED BY THE FIRM/ CONTRACTOR

Sr. No.	Description	Nos. of Each	Owned Or Leased	Year of Purchase	Capacity/ Performance / Size	Present Location

Note: The bidder has to provide undertaking that the above equipment will be made available at project site within the mobilization period. The information provided shall be supported with documentary evidence where required, otherwise no credit/points will be given.

Handwritten signature and initials



FORM – VI:

Registration / Office Facility

Office Facility (Proof of Ownership / Rent) (400Sft Min): _____

Porta Cabin (Detail with proof of ownership / Rent): _____

Computer Facilities (List Items): _____

(1) _____

(2) _____

(3) _____

(4) _____

Handwritten signature and initials

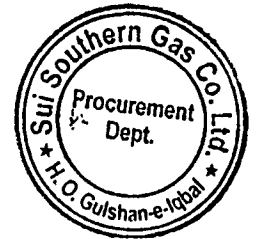

FORM – VII:

Financial Stability

Firm/Contractor applying for technical qualification shall submit the following certificates / registration / statements.

D. Financial Stability

- Attachment of Last Three Year Turnover
- Attachment with details of Cash in hand

Note: In order to be eligible for assignment of marks, Documentary evidence needs to be attached

Handwritten signature
*3. Naveed
CE (Gen)

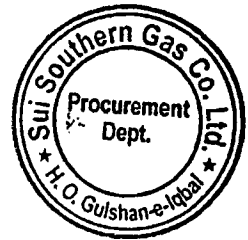

Section - IV
Special Conditions of Tender Document
Tender Enquiry No. SSGC/SC/

Note: In case of any conflict between special conditions of Tender Document and any other terms & conditions, the Special Conditions of Tender Document will govern / prevail.

- 1- Contractor to submit the following within 15 days after issuance of Letter of Intent (LOI).
 - a. Performance Bank Guarantee
 - b. Stamp Papers
 - c. Insurance Policy
 - d. Any other Document as mentioned in the LOI
- 2- Formal contract will be made on Non-Judicial stamp paper of value @ Rs 0.35 per hundred rupees of contract value, as per prevailing rate by Government of Sindh & Balochistan. The stamp duty will be borne by the contractor and also submit the copy of challan of stamp paper. Further as per Government of Sindh Board of Revenue notification NO.CIS/SWB/BOR/R&T-17/2022-808 dated 08-06-2022 all judicial and non-judicial stamp paper of the denomination of rupee five hundred and above shall be exclusively on e-stamp.
- 3- All kinds of Government Taxes, Duties and Levies against any item of the contract, shall entirely be the responsibility of the Contractor. Income Tax will be deducted as per applicable Law under the prevailing Government Rules. Rate of Income Tax deduction in relation to submission of Income Tax certificate from the Contractor should also be stipulated.
- 4- Bank Guarantee (Bid Bond Guarantee/Performance Bank Guarantee) will be made on Non-Judicial stamp paper at the prevailing rate as specified by the respective Provinces. Further the bidder/contractor submitting the Bid Bond guarantee/Performance Bank guarantee being prepared by the State Bank's schedule banks should ensure that there should be no deletion/insertion/alteration/modification of any terms in the Bid Bond/PBG guarantee format as given in the tender document or else bid will be liable for rejection.
- 5- If the letter to proceed (LTP) by user deptt. is not issued within six months after issuance of letter of intent (LOI), both the parties are at liberty to terminate/revoke the LOI without any claim of loss or damage to the other party.
- 6- The completion period of the said work shall start with effect from the issuance of Letter to Proceed, which in case of work exigencies could be issued prior to signing of formal agreement.
- 7- In case of services and works tenders:
Bids determined to be substantially responsive will be checked by the Procuring Agency for an arithmetic error. Errors will be corrected by the Procuring Agency as follows;
 - a. Where there is a discrepancy between the amounts in figures and in words, the amount in words will govern ; ----- and -----
 - b. Where there is a discrepancy between the unit rate and the line item total resulting from multiplying the unit rate by the quality, the unit rates as quoted will govern, unless in the opinion of the Procuring Agency there is an obviously gross misplacement of the decimal point in the unit rate, in which case the line item total as quoted will govern and the unit rate will be corrected.
- 8- The bidder shall fill in rates and prices for all items of the works / services described in the BOQ. Item against which no rate or price is entered by a bidder will not be paid for by the Procuring Agency when executed and shall be deemed covered by rates and prices for other items in the BOQ. **Any Bidder who change / amend the BOQ or Price Schedule (description, Quantity, UOM etc.) will render the bid as conditional bid and will be liable for rejection.**
- 9- **Method For Submission of Bid Bond (Under Single Stage Two Envelope Bidding Procedure):**
In case of Single Stage Two Envelope Tenders the fixed bid bond as per clause#09 of General Terms & Conditions to be placed in the Technical Proposal. However, if the bid bond is placed in the financial proposal will also be considered. Without submission of bid bond (either in Technical proposal or financial proposal) the bid will be rejected.
- 10- Bid bond submission (2%) of the bid amount as mentioned in the clause 9 of General Terms & Conditions, to be treated as null & void, however other contents of clause 9 will remain unchanged. The submission of fixed amount of Bid security is appearing in the Schedule of Requirement/Bid Form.

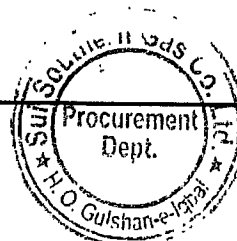

- a) All the bidders are advised to furnish fixed bid security amount appearing in Schedule of Requirement/Bid Form, failing which their bid will be rejected.
- b) The submission of fixed amount of bid security is also mandatory for all the bids valuing Rs.500,000/- or less.
- c) The word lowest bidder or the lowest evaluated bid has been substituted to read as **most advantageous bid**.
- 11- Bid shall remain valid for acceptance for period of (120) days from the date of public opening of the bids & Bid Bond validity is for 150 days.
- 12- In case the local agent requires to offer bid form more than one Principal / Manufacturer, it is mandatory to purchase separate tender document for each Principal / Manufacturer, failing which the bid submitted with the original tender document will only be accepted and the bid with photocopy of tender document will be rejected.
- 13- **Blacklisting Mechanism of Suppliers and Contractors and their Local Agent:**
Black listing mechanism is attached separately in the tender documents which will become an integral part of Tender Documents and now be followed / enforced in true letter & spirit and **supersede the Black listing terms as mentioned in the General Terms & Conditions.**
- 14- Original counter slip of token which is issued with tender document to be attached on the TOP of envelope at the time of bid submission"
- 15- The **Successful Contractor(s) / Supplier(s) / Consultant(s)** shall submit a copy of Professional Tax Certificate with their Invoices / Bills failing which the payment will not be released.
- 16- **Contracts of Contractors**
In the event the contractor is not willing to extend the CONTRACT for further term(s) / Period(s) under the same terms & conditions and the quoted price as defined in the bid documents, the contractor is liable to intimate in writing to SSGC at-least 3 (Three) months in advance prior to completion of the existing contract term / period, failing which, action will be taken as per tender terms.
- 17- **Insurance**
In addition to the Clause 22 –**Insurance**, of General Term and Condition, when The **Successful Contractor(s) / Supplier(s)** will submit Insurance Policy to SSGC, the Insurance Company (policy issuer) should be registered with SECP, otherwise the insurance policy will not be considered / rejected at contractor's risk and cost. The insurance coverage period will be according to the work completion period as mentioned in the contract / tender documents.
- 18- **Fixed Bid Security – Alternative Bid**
A bidder cannot submit two bids/offers with a single fixed bid security/pay order. However, the alternative bids/offers with separate fixed bid security/pay order can be accepted, failing which the bids will be liable for rejection.
- 19- **Bid Bond & PBG (Performance Bank Guarantee) for Proprietary Tenders**
In case of proprietary Tenders, the Bid Bond & Performance Bank Guarantee (PBG) are not required / Applicable.
-
- 20- SSGC will not pay invoices if they are turned in after 6 months of work completion / material delivered.
- 21- It is mandatory for the bidders to follow all the terms and conditions given in the tender documents without any addition / deletion / amendment and submit the bid accordingly. Therefore, in this context, the bidders are requested not to give their own terms and conditions as it tantamount towards the conditional bid. Otherwise their terms and conditions will not be considered and the Purchase Order / Contract will be awarded based on only as per SSGC tender terms and conditions.
- 22- The bidders/contractors are required to provide their only one Bank Account number (IBAN number) on the 'FORM-X' attached duly signed & stamped as one time information, which shall be firm (not changeable) for all the future payment transactions.
- 23- **Payment:**
The supplier after delivery of goods and its acceptance shall submit invoice to Finance Department of the Company, containing following information i.e.
- (a) Purchase order No. & date
 - (b) Items
 - (c) Quantity
 - (d) Price
 - (e) Invoice value
 - (f) Point of delivery
 - (g) Delivery challan indicating delivery date, etc.

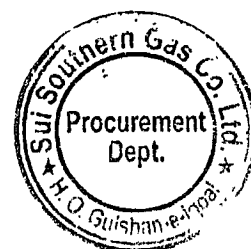

- (h) Supplier(s) are required to submit signed and stamp acknowledgement slip, Sales Tax return, Annex "C" & Annex "I" (whichever applicable) in which Sales Tax (of relevant Sales Tax invoice) is paid.

Payment will be made within 30 days of completion of stated requirements.

23. In case the insurance policy submitted by the contractor is expired during the execution of job, it is the responsibility of the user department to coordinate with the contractor to get it renewed/updated till the period the job is completed/commissioned.

In case the job is not completed within the given time as per tender terms and the insurance policy submitted by the contractor expires, the contractor is liable to get this insurance policy renewed / updated immediately till the period of the job is completed / commissioned as per tender terms failing which the contractor will be responsible for any loss to SSGC.

24. Bidders can quote their rates on both i.e. Schedule of Requirement/Bid Form as well as Bill of Quantity (BoQ)
25. Subsequent to the issuance of LOI, successful bidder has to submit 10% Performance Bank Guarantee of the contract value unless and until specified in the tender document.
26. Company reserve the right to award the Purchase Order /LOI to most advantageous bidder.
27. As per SRO 592(I)/2022 of PPRA Regulations, for Procurement Contracts/Purchase Orders worth of Rs. 50 million and above, bidders/contractors are required to submit the Beneficial Owner's Information for Public Procurement Contracts/Purchase Orders (Annexure-I).
28. Bidder will be blacklisted and henceforth cross debarred for participating in respective category of Public Procurement proceedings for a period of (not more than) six months, if fail to abide with a bid securing declaration (which is an integral part of tender document), however, without indulging in corrupt and fraudulent practices, if in breach of obligation(s) under the Bid conditions:
- The bidder have withdrawn or modified their bid during the period of bid validity as specified in the tender terms.
 - Having been notified of the acceptance of bid by procuring agency during the period of bid validity (i) failure to sign the contract or accept purchase order (ii) fail or refuse to furnish the performance security or to comply with any other condition as mentioned in the tender document.
29. Wherever the "Rate Only" is mentioned (either on BOQ or anywhere in tender documents) the same shall only be applicable not exceeding 15% of the original procurement for the same items as given in the BOQ for package basis. In case the requirement is on item wise basis (not package basis) then not exceeding 15% of the original Procurement for the same items (on item wise basis) as given in the BOQ.
30. **Lots:** In case when the tender is floated on LOT basis, following clauses to be applied:
- The bidder(s) are essentially / mandatorily required to submit fixed bid bond as mentioned in the bid form/BOQ/Invitation to Bid. Separate fixed bid bond to be submitted against each individual LOT and its validity to be 150 days at the time of opening of technical proposal.
 - Evaluation for each LOT will be carried out separately. Each LOT will be awarded separately.
31. For open competitive bidding if the most advantageous bidder is new local manufacturer, 10% trial order will be placed and remaining 90% order will be awarded to the next most advantageous bidder at their own quoted rates.
32. Redressal of Grievances And Settlement of Disputes:
- Any bidder feeling aggrieved by any act of the procuring agency after the submission of his bid may lodge a written complaint concerning his grievances within seven days of announcement of the technical evaluation report and five days after issuance of final evaluation report.
 - In case, the complaint is filed against the technical evaluation report, the GRC shall suspend the procurement proceedings.
 - In case, the complaint is filed after the issuance of final evaluation report, the complainant cannot raise any objection on technical evaluation of the report. Provided that the complainant may raise the objection on any part of the final evaluation report in case where single stage single envelope bidding procedure is adopted.

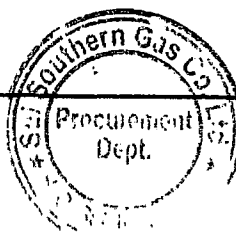

SECTION - V

General Terms & Conditions**1. Definitions and Interpretation:**

1.1

In these tender documents (as hereinafter defined) the following words and expressions shall have the meaning hereby assigned to them except where the Tender requires otherwise.

- a) **Company** means the Sui Southern Gas Company Limited; a Company registered under statutes of Pakistan and includes any successors-in-interest or assignees.
- b) **Engineer** means the Engineer(s) nominated by the Company to look after and supervise the Work.
- c) **Representative of the Company** means a duly authorized person appointed by the Company or as specified in the "Special Conditions of the Contract" to perform the assigned duties.
- d) **Bidder** means any person or persons, firm or company bidding for the Work.
- e) **Contractor** means the persons, firm or company whose Tender (as hereinafter defined) has been accepted by the Company and includes the Contractor's representatives, sub-Contractors, successors and permitted assignees (Prior to the execution of the Contract the word "Contractor" also means a Tenderer or Bidder submitting a proposal in accordance with the Tender Documents).
- f) **Agent or Representative** means person(s) appointed by the Contractor to perform duties as set forth in the Contract.
- g) **Laborers/Workmen** means such laborers/workmen and staff as may be employed by the Contractor for purpose of carrying out the Work.
- h) **Sub Contractor** means any firm or person having a direct Contract with the Contractor. Nothing contained herein however, shall be deemed or be construed to impose upon the Company, any obligation, liability or duty to a sub-contractor or to create any contractual relation between any sub-contractor and the Company.
- i) **Work** means whole of the Works / Services or part thereof to be executed in accordance with Tender / Contract documents, whether temporary or permanent and whether original, altered substituted or additional.
- j) **Contract Documents** shall consist of duly executed Articles of Agreement, the Tender Documents and the Tender submitted by the successful Bidder including modifications thereto incorporated in the documents before and after the execution of the Contract.
- k) **Contract Price/Value** means the sum named in Schedule of (SOR) / BOQ subject to additions thereto or deductions there from as may be made under the provisions hereinafter contained.
- l) **Plant** means all machineries, equipment, materials, appliances or things of whatsoever nature required in or about the execution, completion or maintenance of the Work, but does not include such equipment, materials, appliances or things intended to form part of the permanent Work.
- m) **Temporary Works** means all temporary works of every kind required in or about the execution, completion or maintenance of the Work.
- n) **Drawings** means the drawings referred to in the Contract documents and any modification of such drawings.
- o) **Location** means the land and other places on, under in or through which the Work is to be executed or carried out and other lands or places provided by the Company for the purpose of the Contract.
- p) **Approved/Approval** means approved/approval in writing by Company's representative or as specified in "Special Conditions of Contract".
- q) **Tender/Bid** means the offer tendered by the Bidder for the Work governed by the Contract.
- r) When the terms Acceptable, Satisfactory, Proper, or other such general qualifying terms are used in the Contract, it shall be understood that reference is made to be sole ruling and the sole judgment of the Company.
- s) The Word Equivalent or Equal where used in these documents in the general sense shall not mean Similar but shall mean "Conforming to, Like, of Kind/Quality and Function". "Proprietary Items" and "Trade Names" are used for the purposes of establishing a standard of "Kind, Quality and Function" and "Equipment" items, articles, things or materials will be approved, if held to be "Equivalent" by the Company.
- t) **Approved Banker** wherever occurring in this Contract shall mean a Scheduled Commercial Bank operating in Karachi and acceptable to the Company.

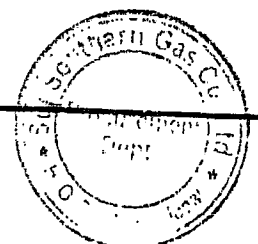
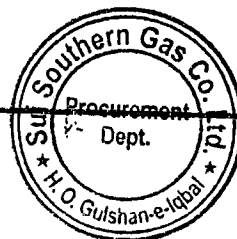

- u) **Specification(s)** means the standard codes of practice and other specifications issued with the Tender and any notification such as specifications approved in writing by the Company and other specifications as may from time to time be furnished or approved in writing by the Company.
 - v) **Month** means calendar month of the Christian era.
 - w) **Time Schedule** is a graphical illustration of the time span of various Work activities defining starting and completion dates.
 - x) **Bonds** mean Bid Bond, Performance Bond or Bank Guarantee and other instruments of security furnished by the Bidder of his surety in accordance with the Tender/Contract.
 - y) **Completion Date** means the date on which the Work has been completed in accordance with the Contract so that it can be utilized for intended purpose.
 - z) **Day** means a day of 24 hours mid night to mid night.
 - aa) **Completion Period** means the time allowed for the execution of the Work.
- 1.2 Words importing the singular only also include the plural and vice-versa where the Contract so requires.
- 1.3 The marginal headings or notes in these Conditions of Contract shall not be deemed to be part thereof or be taken into consideration in the interpretation or construction thereof or of the Contract.
- 1.4 If there is any conflict between the Special Conditions and the General Conditions, the Special Conditions shall modify, supplement and supersede the General Conditions.
2. **Examination:**
Bidders shall visit/inspect/examine the Work & Location and shall fully acquaint themselves with the nature and requirements of Work/Services, access to Work/Location, availability of materials, weather, law and order and local conditions etc. before submitting their Bids. Submission of the Bid shall be prima facie evidence that the Bidders have fulfilled this requirement and shall be binding upon him.
3. **Conflict between Drawings/Specifications/SOR:**
In case of any conflict between drawings/specifications, SOW/TOR and SOR/BOQ, with regard to the quality of any item, the Contractor / Consultant shall base his quotation for the better quality. In case of any deficiency in the drawings/details, the Contractor / Consultants shall seek clarification from the Company. Submission of Bids/rates on the basis of incomplete drawings/details shall be Contractor / Consultant's sole responsibility.
4. **Additions, Deletions:**
The Company reserves the right to make addition (Upto 15 %) and delete the quantity from the Work defined in SOW/TOR/SOR/BOQ as deemed necessary before or after the execution of the Contract. All such additions and deletions shall only be authorized in writing by the Company.
5. **Schedule of Requirement:**
The quantities specified in the SOR/BOQ are estimated and are intended to serve only as a guide to the Bidders. Payments shall be made on the basis of actual Work quantum done as measured. No claims or adjustments shall be entertained/allowed on account of increase or decrease in the Scope of Work which has not been duly authorized by the Company through the issue of change orders as stipulated in the relevant provision.
6. **Rate:**
The Bidder shall quote all item rates and lump sum prices as shown in the "SOR/BOQ". Bidders shall fill in the rate / price for each item in the SOR/BOQ. In case of any discrepancy between item rate and the amount, the quoted item rate will prevail. The quantities given in the SOR/BOQ are estimated ones and are subject to variations. That is, there could be increase or decrease. Nevertheless, the item rates quoted by the Bidder shall remain fixed and no escalation whatsoever shall be permissible. The rates / prices quoted by the Bidder shall be workable. The Bidder shall be required to furnish a complete rate analysis of any item in the SOR/BOQ as considered necessary, by the Company.
7. **Escalation:**
It may be clearly understood that this tender does not contain a price variation clause and therefore, all unit prices quoted shall be firm, irrevocable fixed and valid until completion of the Contract and will not be subject to variation on any account.
8. **Validity:**
Bids shall remain valid for acceptance for a period of (120) days from the date of bid opening. If the last date falls on a holiday, the validity will be extended to the first Company working day thereafter.
9. **Bid Bond (Earnest Money):**
The Bidder is required to furnish Bid Bond strictly in accordance with the prescribed format, in the form of a Pay Order, Demand Draft or Bank Guarantee issued only by a scheduled commercial bank operating in Karachi, for an amount fixed bid bond as specified of tendered Work / Services quoted by the Bidder in favor of Sui Southern Gas Company Limited. No Bid shall be considered without a Bid Bond and no cash or cheque or a guarantee issued by an insurance company shall be accepted.

The Bid Bond shall remain valid for a period of 150 days from the date of Bid opening. Bid Bonds of the unsuccessful Bidders shall be returned as soon as practicable, The successful Bidder's Bid Bond shall be retained by Company until execution of a Contract for the Work / Services defined in these documents and the submission of a Performance Bond prior to the execution of Contract.

In the event that the successful Bidder refuses or fails to provide (PBG) and Stamp papers for contract within fifteen (15) days of the issuance of a Letter of Intent, Company shall be at liberty to forfeit the Bid Bond.

In the event of the bid bond validity falling short of the prescribed period of 150 days as the case may be either (i) due to extension in the bid submission date or (ii) where so required by the procuring agency, than in such an event it shall be mandatory on the bidder to extend the bid bond validity up to 150 days within 30 days of the opening of technical proposal / bid, and / or where so required by the procuring agency.

In case when bidder submit alternate bids a separate bid bond for each bid is required otherwise bid will be liable for rejection. In case of Single Stage Two Envelope bidding system (bid bond will be enclosed with "Financial" bid, unless and until specified separately in Tender terms).

The bid bond may be forfeited if a bidder withdraws the bid during validity period specified by the bidder or if successful bidder fails to:

- > Accept purchases order/LOI,
- > Furnish performance guarantee in accordance with clause 10 of General Terms & Conditions,
- > Extend Services as per requirement and completion Period.

10. Performance Bond:

The Bidder shall furnish a Performance Bond strictly (if the bid increases to Rs. 500,000/-) in accordance with the prescribed format in the form of a bank guarantee issued by a scheduled commercial bank operating in Karachi for an amount equivalent to FIVE (05) percent of the Contract value. Failure to furnish the performance Bond before execution of the Contract will entitle the Company to consider the Bidder as having abandoned the Contract and the forfeit the Bid Bond. The Performance Bond shall remain valid till after three (03) month of completion of the work.

The Company's right to recover damages from the Bidder for breach of Contract shall not be limited to the value of the Performance Bond. In the event of the Bidder failing to execute a formal Contract or to submit the Performance Bond in the manner aforesaid and in the period specified, the Company shall be entitled to appropriate the earnest money submitted by the Bidder with his tender without prejudice to its right to claim any further loss or damage which may result to it by reason of the aforesaid default of the Bidder as if Contract is actually executed for the purpose of such claims.

The Bidder shall extend the validity period of the Performance Bond for such period(s) as required for the Contract performance.

The performance bond of the successful bidder will be released after successful completion of work.

11. Retention Money:

The amount to be retained from payments shall be equal to the specified percent of certified value of Work which would be released after the maintenance period.

12. Completion Period:

Subject to any requirements as to completion of any portion of the Work before the completion of the whole of Work, the Work shall be completed within the specified completion period. The Work shall not be considered as completed until the Company has certified in writing that it has been completed. Should extra, altered or additional Work of any kind, or any other cause of delay, which in the opinion of the Company could not have been foreseen by the Contractor / Consultant requires extension in completion time, then on the written request of the Contractor / Consultant, the completion period as provided in the Contract shall be extended by the Company. All such extensions shall be allowed in writing by the Company's representative.

13. Signing / Execution of Contract / Agreement:

Formal signing / execution of Contract / Agreement shall be completed within fifteen (15) days of receipt of "Letter to Proceed". The Company shall prepare the Contract in accordance with the prescribed format (Contract Form, and Articles of Agreement) for the purpose and the successful Bidder shall be communicated the date and time by the Company for the execution of Contract.

The successful Bidder shall provide the stamp paper, of value at the rate of thirty five (35) paisa per every hundred Rupees or part thereof of the amount of the Contract, or at the prevailing rate as specified by the Government of Pakistan.

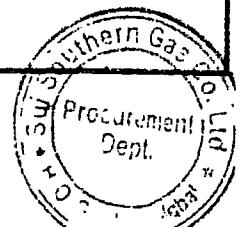

In case the agreement is executed for services i.e Janitorial, Canteen, Landscaping, Maintenance Contract etc.... will be for One year extendable for further Two terms of one year each unless specified in Special Term & conditions.

14. **Award / Evaluation Criteria:**

Company reserves the right to settle the final award of job to the technically compliant and lowest evaluated and commercially responsive bidder.

Evaluation may be carried out both on item or on group of items/single or multiple package basis depending upon the nature of requirement exclusively at the discretion of the company to ensure economic procurement.

15. **Commencement & Execution of Work:**

Notwithstanding any delay in the preparation / execution of the Contract the successful Bidder shall commence mobilization / preparations and under take the Work within (15) days after receipt of the Letter to Proceed.

The Contractor / Consultant shall prior to commencement of Work, obtain the written authority and instructions of the Company.

16. **Change in Orders:**

The Company may at any time, by a written notice to the Contractor / Consultant, make changes within the general Scope of Work of the Contract.

Upon notification by the Company of such change, the Contractor / Consultant shall submit to the Company an estimate of costs for the proposed change (hereinafter referred to as a change) within ten (10) calendar days of receipt of notice of the change, and shall include an estimate of the impact (if any) of the change on the completion date (s) under the Contract, as well as detailed schedule for the execution of the change, if applicable.

The Contractor / Consultant shall not perform changes in accordance with above, until the Company has authorized a Change Order in writing on the basis of the estimate provided by the Contractor / Consultant.

Changes mutually agreed upon as a change shall constitute a part of the Work under this Contract, and the provisions and conditions of the Contract shall apply to said change.

17. **Assignment:**

The Contractor / Consultant shall not assign, in whole or in part, its obligations to perform under the Contract except with the Company's prior written consent.

18. **Termination of Contract:**

The Company may decide to terminate the Contract in one of the following situations:

(i) **Termination for Default:**

The Company may, without prejudice to any other remedy for breach of Contract, by written notice of default sent to the Contractor / Consultant, terminate the Contract in whole or in part.

- (a) If the Contractor / Consultant fails to complete the contracted Works / Services within the time period(s) specified in the Contract or any extension thereof granted by the Company.
- (b) If the Contractor / Consultant fails to perform any other obligation(s) under the Contract.
- (c) If the Company during the completion period of the Contract has reason to believe that the Contractor / Consultant will not be able to fulfill the obligations under the Contract.

Prior to the exercising of any right by the Company to terminate the Contract, the Company shall issue notice to the Contractor / Consultant specifying the default(s) and the Contractor / Consultant shall submit an explanation within seven (07) days of receipt of such notice. If such explanation is not furnished within the stipulated time or if so furnished, is found to be unsatisfactory and / or the default(s) continues, the Contract may be terminated by the Company.

(ii) **Termination for Insolvency:**

The Company may at any time terminate the Contract by giving written notice to the Contractor / Consultant, without compensation to the Contractor / Consultant, if the Contractor / Consultant becomes bankrupt or otherwise insolvent. Notwithstanding the above such termination will not prejudice or affect any right of action or remedy which as accrued or will occur thereafter to the Company.

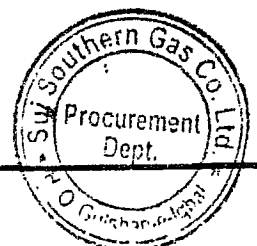

(iii) **Termination for Convenience:**

- a. The Company may by written notice sent to the Contractor / Consultant, terminate the Contract, in whole or in part, at any time for its convenience. The notice of termination shall specify that termination is for the company's convenience, the extent to which performance of work under the Contract is terminated and the date upon which such termination becomes effective.
- b. The Works that are complete and ready for Commissioning within thirty (30) days after the Contractor / Consultant's receipt of notice of termination shall be at the Contract prices and on the existing Contract terms. For the remaining Works, the Company can also opt to have any portion thereof completed and commissioned at the contract prices and on the other contract terms.

19. **Liquidated Damages:**

If the Contractor / Consultant fails to complete the Work or perform the Services specified in the Contract within the stipulated period / scheduled time specified in the Contract, the Company, without prejudice to any other remedies, shall deduct from the bills or any other due payments / guarantees, as liquidated damages, a sum equivalent to 0.1 % per day of the value the Contract, until actual completion of the Work or performance of the Services. However if delay of over 100 days takes place (i.e. equal to 10%), the Company reserves the right to terminate the Contract at the risk and cost of Contractor / Consultant. The liquidated damages shall also be applicable for the Works / Services terminated under Clause 16.

The payment of liquidated damages shall not relieve the Contractor / Consultant from performing and fulfilling all its obligations under the Contract and nor shall the rights and entitlements of the Company be affected or reduced in any manner.

20. **Force Majeure:**

The parties will not be considered to be in default in the execution of their contractual obligations or any of them to the extent that the execution of such obligations or any of them is delayed or omitted by cause of Force Majeure. Each party will advise the other party by written notice within 07 days of the occurrence of any such case of Force Majeure. The term Force Majeure employed herein shall mean acts of public enemy, wars (whether declared or not) invasion, hostilities, revolution, epidemics, riots (other than among the Contractor / Consultant's own employees) fires, floods, earth quake, commotion, disorder and other causes similar in kind to those herein mentioned, not under the control of either party, which makes the performance of this agreement unfeasible and which by the exercise of due diligence the party seeking excuse from performance is unable to overcome.

The Company shall not be liable to the Contractor / Consultant for any damage or loss caused by Force Majeure directly or indirectly.

21. **Safety of Employees and Works:**

The Contractor / Consultant shall be responsible to take all necessary precautions for the safety of employees on or off the Work, and shall comply with all applicable safety laws and codes to prevent accidents or injury to persons on about or adjacent to the places where the Work is being performed. All statutory rules, orders, regulation from time to time in force relating to taking and observance of all safety precaution governing or which might be deemed to be given during the execution and performance of the Work. The Contractor / Consultant shall comply with any and all personnel safety regulations. Any person of the Contractor / Consultant violating the safety rules shall be removed by the Contractor / Consultant from site and replaced without delay.

22. **Insurance:**

The Contractor / Consultant shall be responsible for obtaining a Contractor / Consultant's All Risk Policy (CAR) against risks to the Works and shall make good at his own cost, all losses or damages whether to the Works or to the lives, persons, whether under the workmen's compensation Act or Third Party Risk, or property of others from whatsoever cause arising out of or in connection with the works either during the progress of the works or during the period of maintenance provided by this Contract.

The Contractor / Consultant shall arrange insurance approved by the Company fully to cover workmen compensation and other claims arising out of sickness, injury or death of his personnel working at site and also to cover theft, loss of or damage to the Company's material in his possession and to indemnify the Company for third party claims for damage done or said to have been done to those persons or their property as a result of the Contractor / Consultant's activities on and off the site.

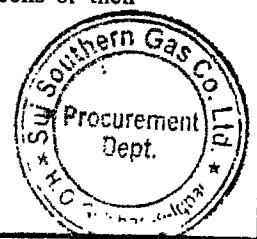

Insurance will be required where ever applicable:**Company's Address:**

**GENERAL MANAGER (PROCUREMENT)
SUI SOUTHERN GAS COMPANY LIMITED,
2ND FLOOR, HEAD OFFICE, ST-4/B, B-14,
SIR SHAH SULEMAN ROAD,
GULSHAN-E- IQBAL,
KARACHI - PAKISTAN.**

Contractor / Consultant's Address:

23. Dispute Resolution:

If any dispute shall arise as to the interpretation of this Contract or any matter or thing arising there from, the same shall be settled as far as possible by way of amicable resolution. Failing such settlement, the dispute may be referred for arbitration to two Arbitrators, one to be nominated by each Party. The appointed Arbitrators shall before proceeding on the reference appoint an Umpire. The Award given by the Arbitrators or the Umpire as the case may be shall be final and binding on the Parties. The proceedings shall be governed by the Pakistan Arbitration Act, 1940 and any statutory modification thereof. The venue of arbitration shall be Karachi.

All costs of Arbitration shall be borne by the Parties themselves, unless otherwise ordered by the Arbitrator. Notwithstanding the existence of any difference or dispute, or the commencement or continuance of any arbitration proceedings, Works to be done or Services to be provided under this Contract shall not be suspended or discontinued by the Contractor / Consultant nor shall any payment be withheld by the Company except the difference of the amount in dispute, which is the subject matter of such proceedings.

24. Income Tax and Duties:

All kinds of Government Taxes and Duties (income tax, custom duties, etc.) also the provincial sales tax as per provincial law, against any item of the contract, shall be entirely the responsibility of the Contractor / Consultant. Income Tax will be deducted as applicable under the prevailing Government Rules. Rate of Income Tax deduction in relation to submission of Income Tax certificate from the Contractor / Consultant should also be stipulated.

All Foreign Service providers are required to obtain Advance Ruling from the Federal Board of Revenue (FBR) under Section 206A of the Income Tax Ordinance 2001 (Pakistan's Income Tax Law). The advance Ruling issued by FBR covers application of Income Tax Ordinance 2001 to Transaction proposed or entered in to Foreign Service Provider".

25. Payments:

Payment will be made within 30 days after completion of works.

The Contractor / Consultant shall submit to the Company during the execution of the Work on-account bills along with a statement / details of executed Work.

The rates and prices in such on-account bills and statement of Work shall be in accordance with those in the SOR/BOQ so far as such rates and prices are applicable and on the approved rates and prices for other items of Work. All payments against on-account bills shall be treated as provisional payments and will be subject to final adjustment.

The Company may withhold payment or on-account of subsequently discovered evidence, nullify the whole or part of any certificate to such extent as may be necessary to protect itself from loss on-account of:

- (a) Defective Work not remedied.
- (b) Claims filed or reasonable evidence indicating probable filing of claim.
- (c) Failure of the Contractor / Consultant to make payments properly to Sub-Contractor / Consultants.
- (d) Damage to another Contractor / Consultant.

When the grounds are removed payment shall be made for amounts withheld because of them.

Payments in respect of extra / additional Work will be made on the basis of the original Contract rates and the Contractor / Consultant will not be entitled to any extra compensation / payment including idle charges because of such delays.

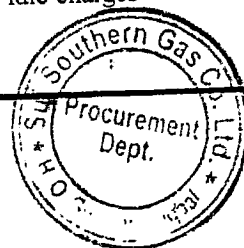

The making and acceptance of the final payment after successful completion of Work shall constitute a waiver of all claims by the Company other than those arising from faulty Work appearing after final payment and of all claims by the Contractor / Consultant, except those previously made and still unsettled.

Supplier (s) are required to submit signed and stamped acknowledgement slip, Sale Tax return, Annex "C" & Annex "I" (whichever applicable) in which Sales Tax (of relevant Sales Tax invoice) is paid.

26. Blacklisting of Suppliers and Contractor / Consultants:

The company shall permanently blacklist or temporarily debar (at least for 6-months from participating in SSGC's tender proceeding) if, a supplier or Contractor / Consultant who either constantly fails to perform satisfactorily or found to be indulged in corrupt and fraudulent practices as defined below:

- 26.1 Corrupt and fraudulent practices" includes the offering, giving, receiving, or soliciting of anything of value to influence the action of an official/company.
- 26.2 If the supplier/Contractor/ Consultant found responsible for the detriment of the company during proceedings of procurement/contract, process or its execution.
- 26.3 Misrepresentation of facts (by providing fake documents, concealing/ mis-reporting facts pertaining to the bid) in order to influence the procurement process or the execution of the purchase order/contract.
- 26.4 Collusive practices among bidders (prior to or after bid submission) designed to establish bid prices at artificial, non-competitive levels and to deprive the company of the benefits of free and open competitive.

27. GOP's Obligation:

The contract shall be governed by the Law of Pakistan. The Contractor / Consultant is obligated to comply with all regulations and ordinance in force or to be passed by the Government of Pakistan in connection with Labor legislation during the course of the work to be performed. Any additional financial charges on account of revision in minimum wages by GOP will be company's responsibility while the contract is in operation.

This contract embodies the entire understanding of the parties hereto on this subject and there are no commitment, terms, conditions or obligations, oral or written, express or implied, other than those contained herein.

28. Late Bid:

Sealed bids shall be mailed/submitted/dropped in tender box placed at Tender Room, CRD Building, and SSGC Head Office, In accordance to the time specified in invitation to bid & tender notice (which ever applicable), Bids are to be delivered on or before closing time after which all bids submitted after the time prescribed shall not be entertained and will be returned without being opened. In case bid is sent through courier, the same shall be delivered at least half an hour before scheduled opening time.

29. Rebate / Discount:

Unit rate (s) given in the Bill of Quantities shall take into account all relevant factors including discount if any. Discount given separately at the time of bid opening will not be considered.

30. Joint Ventures:

In the event that the bidder is bidding as a Joint Venture, the Company will require the joint venture agreement duly executed by the parties to the Joint Venture to be submitted with the bid. The joint venture parties shall also furnish an undertaking to be jointly and severally liable for all liabilities arising out of obligation under the Purchase Order / Contract. The, Joint Venture agreement of the parties must specify share of each partner and name of the lead partner along with their registration with the FBR, SST and BST as the case may be failure to specify these two narrations the joint venture agreement will not be entertained.

31. Correction / Amendments in Quoted Price:

Any overwriting in BOQ / SOR is not allowed. In case of type of any amendment / correction required in unit price / total amount the same has to be strikeout and re-written with corrected figures, properly signed & stamped out, in order to avoid an ambiguous bid.

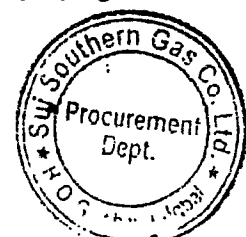

FINANCIAL
PROPOSAL



SECTION-VI**TENDER FORM**

Note: This section forms a part of the tender. Bidders are required to fill in the blank spaces, sign and stamp on this tender form

Sui Southern Gas Company Limited,
ST 4/B, Block 14, Sir Shah Muhammad Suleman Road,
Gulshan-e-Iqbal,
KARACHI.

**Construction of Boundary Wall Enclosure, CC Flooring & Guard Room
with Bathroom at TBS Bin Qasim Industrial Park, Karachi**

Tender Ref No. CIV-P&D-P&C 2K2446

Dear Sir,

1. Having examined the Site, Drawings, Conditions of Contract, Scope of Work and Bill of Quantities for the subject Work, I/We, the undersigned offer to undertake, complete and maintain the whole of the said Work in conformity with the contract terms the unit rates given.
2. I/We undertake, if my/our tender is accepted, to commence the Work within specified time after receipt of the letter of intent/letter to proceed/signing of contract, and to complete and deliver the whole of the Work contained in the contract within the period specified in the tender document.
3. I/We agree to abide by this tender for the period of **150 days** from the date fixed for opening the same and it shall remain binding upon me/us and may be accepted at any time before the expiration of this period.
4. I/We agree to execute the Work in a manner satisfactory to the Company whose decision shall be final and without appeal on work methods, specifications, and quality of materials, equipment and workmanship.
5. I/We agree to supervise and furnish adequate engineering and supervisory staff, labour force, tools, plants, machinery and finances to perform the Work in time as specified in the agreed Time Schedule to ensure that all will be done in accordance with accepted international engineering standards.
6. Unless and until a formal agreement is prepared and executed, this tender together with the Company's written acceptance shall constitute a binding contract between us.
7. I/We understand that the Company is not bound to accept the lowest or any tender received without assigning any reasons.
8. For ease of reference certain information and special stipulations applicable to the contract within the subject of the tender are set forth herewith:

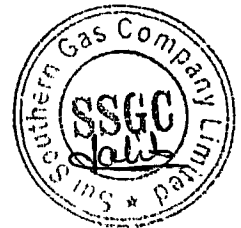
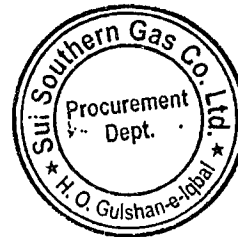

- a. Name of the Company : **Sui Southern Gas Company Limited**
- b. Name of Work : **Construction of Boundary Wall Enclosure, CC Flooring & Guard Room with Bathroom at TBS Bin Qasim Industrial Park, Karachi**
- c. Amount of Bid : Rs. _____
(To be filled in by the Bidder)
- d. Date of award of Work : Date of acknowledgement of Letter of Intent (LOI) by the Bidder
- e. Mobilization Period : **Fifteen (15) days** from the date mentioned in the Letter to Proceed (LTP)
- f. Performance Bond : **Five (5%) Percent** of the Contract / Bid Value as as per Clause 6. Section-IV "Special Conditions of Contract"
- g. Retention Money : Deduction at the rate of **(5%) percent** from the progress and final payments
- h. Completion Period : **Six (06) Months** from the date mentioned in Letter to Proceed (LTP).
- i. Mode of Payment : As per Clause 12 Section-IV "Special Conditions" of Tender Enquiry
- j. Maintenance Period : **Six (06) Months** from the date of completion.
- k. Liquidated Damages : **0.1% percent** of contract value for each day of delayed services to a maximum of Ten 10% of the total contract value.
- l. Insurance (CAR) : Contract Value + 10% of contract value

Name of bidder or authorised representative _____
(In block letters)

Dated this _____ day of _____ 2024.

Signature: _____

In the capacity of _____ duly authorized to sign the tender

For and on behalf of _____
(Name of Company with seal/stamp)

Witness

Signature: _____

Name : _____

Address : _____

**-13*
10/10/24
Secy
PDC

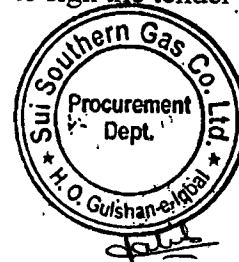

SECTION – VIII

BILL OF QUANTITIES



SECTION VIII**Construction of Boundary Wall Enclosure, CC Flooring & Guard Room with Bathroom at TBS Bin Qasim Industrial Park, Karachi**

Tender Ref# CIV-P&D-P&C 2K2446

BILL OF QUANTITY

Item No.	Description	Unit	Quantity	Rate Rs.	Amount Rs.
	Providing all labor, material and equipment for construction of following works complete in all respects as per scope of work Section III (A & B), attached drawing, as per site requirements and as directed by Engineer Incharge				
A.	Boundary Wall (Including 16 ft wide Main Gate)	Rft	400		
B.	Earth Filling (Compacted)	Cft	9,000		
C.	CC Flooring	Sft	10,000		
D.	Guard Room (12'x12' Internal Size) With Washroom (8'x8' Internal Size)	Lumpsum/ Job	1		
E.	Under Ground Water Tank (6' x 6' x 8' Internal Size)	Lumpsum/ Job	1		
TOTAL					

*H. S. Hossain
C.E.O.
P&C

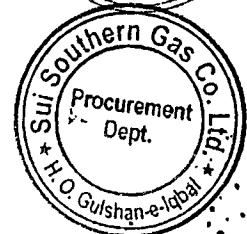

Report Run by : DESKTOP-D30VR27
Enquiry No. SSGC/SC/13432

TENDER ENQUIRY NO. SSGC/SC/13432

SECTION-VII

SCHEDULE OF REQUIREMENT
AND
BID FORM

Sr. NO.	DESCRIPTION OF ITEMS / PART NOS. (1)	QUNATITY (3)	UOM (4)	TOTAL AMOUNT
1	[1] SC644964 <u>Delivery Schedule:</u> CIVIL WORKS FOR CONSTRUCTION OF BOUNDARY WALL ENCLOSURE, CC FLOORING & GUARD ROOM WITH BATHROOM AT TBS BIN QASIM INDUSTRIAL PARK, KARACHI (AS PER BOQ)	1.00	Lot	

Fix Bid Bond Amount in PKR: 200,000

NOTE :

- (i) The quoted unit price and corresponding total amount shall be inclusive of all duties & Taxes, excluding Sales Tax as per provincial laws.
- (ii) Incase of supply of material alongwith services GST will be exclusive of quoted rate of material.
- (iii) Bidders are essentially required for quote their rates on bid form / BoQ.
- (iv) Prices given in the bid form and BOQ shall take into account all relevant factors including discounts, if any. Discount given separately at the time of bid opening will not be considered.
- (v) Any Bidder who change/amend the BOQ or Price Schedule (description, quantity, uom etc.) will be render the bid as conditional bid and will be liable for rejection.

SIGNAUTRE OF BIDDER: _____
NAME.....: _____
NAME OF BIDDER.....: _____
STAMP.....: _____
DATE.....: _____

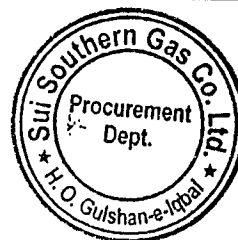

Doc No. _____
 Rev: 0
 Date: _____

Quality Inspection Plan
Construction of Boundary Wall Enclosure, CC Flooring & Guard Room with Bathroom at TBS BQIP

Client:		Project:		Location:		Remarks				
Contractor:		Responsibility		Applicable Codes		Inspection Description		Test Required		
S.No	Divisions	Inspection Stage	Check Points	Contractor Site Engineer						
1	Foundation	1.1	Excavation	Contractor Site Engineer		Check the size of the trench suitable for safe working.				
		1.2	Stone Soling		VI	Check the size of gravels suitable for proper compaction.				
		1.3	Lean Concrete		H	Check the proper ratio of cement .aggregates and water.				
		1.4	RCC Footing		H	Check the proper thicknss . spacing and dia of steel bars.	ACI 318	Cube Test		
		1.5	Reinforcement		H	Check the dia & spacing of steel bars.	BS 4449			
2	Plinth	2.1	RCC Plinth Beam		ACI 318	Check the proper ratio of cement .aggregates and water.	Cube Test			
		2.2	RCC Short Columns	H	ACI 318	Check the proper ratio of cement .aggregates and water.	Cube Test			
		2.3	Reinforcement	H	BS 4449	Check the size of beams and dia & spacing of steel bars.				
3	Flooring	3	Compaction Of Earthfilling			Check whether the compaction is done in layers.	Proctor Test			
5	Super Structure	4.1	Block Masonry			Check the required dimensions and quality of Blocks				
		4.2	Columns	H	ACI 318	Check proper ratio of cement .aggregates and water.	Cube Test			
		4.3	Beams	H	ACI 318	Check proper ratio of cement .aggregates and water.	Cube Test			
		4.4	Reinforcement	H	BS 4449	Check the size of beams / Columns and dia & spacing of bars.				
6	Roof	5.1	Roof		ACI 318	Check the proper ratio of cement .aggregates and water.	Cube Test			
		4.4	Reinforcement	H	BS 4449	Check the size of Slab and dia & spacing of bars.				
6	Paint	6.1 -	Paint			Check the quality and application of paint on each member as per scope of work.				

* S
 Muzki
 Checked
 PSC

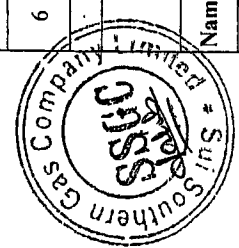
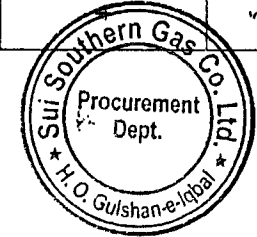

VI: Visual Inspection
 W: Witness (Client/ Contractor Representative)
 H: Holding (will be hold till witness & go ahead signal by client representative)

CLIENT
 Approved By
 Name: _____
 Designation: _____
 Signature: _____
 Date: _____

Checked By
 Name: _____
 Designation: _____
 Signature: _____
 Date: _____

Name: _____
 Designation: _____
 Signature: _____
 Date: _____

SECTION VIII**Construction of Boundary Wall Enclosure, CC Flooring & Guard Room with Bathroom
at TBS Bin Qasim Industrial Park, Karachi**

Tender Ref# CIV-P&D-P&C 2K2446

Engineer Estimate

Item No.	Description	Unit	Quantity	Rate Rs.	Amount Rs.
	Construction of subject work as per scope of work Section III and as per Drawings Section IX complete in all respect as per site requirements and as directed by engineer incharge				
A.	Boundary Wall	Rft	400	11,664	4,665,540
B.	Flooring				
B1	Earth Filling	Cft	9,000	40	360,000
B2	CC Flooring	Sft	10,000	250	2,500,000
C.	Guard Room (12'x12' Internal) With Washroom (8'x8' Internal)	Lumpsum	1	1,700,000	1,700,000
D.	Under Ground Water Tank (6' x 6' x 8' Internal)	Lumpsum	1	580,000	580,000
TOTAL					9,805,540



(On Stamp Paper @ Rs.100 for first Rs.100, 000 and Rs.50 per subsequent Rs.100, 000 of Guarantee Value)

BID BOND FORMAT

Sui Southern Gas Company Limited,
ST-4/B, Sir Shah Muhammad Suleman Road,
Block 14, Gulshan-e-Iqbal,
Karachi.

Tender Enquiry No SSGC / SC /

Dear Sirs,

In consideration of Messrs _____ hereinafter called "The Bidder" having submitted the accompanying bid and in consideration of value received from _____ we hereby agree to undertake as follows:

1. To make un-conditional payment of Rupees _____ upon your return demand without further recourse, question or reference to the Bidder or any other person, in the event of the with drawl of the aforesaid Bid by the Bidder before the end of the period specified in the Bid after the opening of the same for the validity thereof, or if no such period to be specified within 120 days after said opening and or in the event that the Bidder within the period specified thereof, or if no period be specified with 15 days after prescribed forms are presented to the Bidder of signature the Bidder shall fail to execute such further contractual documents if any as may be required by the Company, or on the Bidders' failure to give the requisite Performance Bond as may be required for the fulfillment or resulting Contract with 10 days of the acceptance of the Bid.
2. To accept written intimation(s) from you as sufficient evidence of the existence of default or non compliance as aforesaid on the part of the Bidder and to make payment immediately upon receipt of the written intimation.
3. No grant of time or other indulgence to, or composition, or arrangement with the Bidder in respect of the aforesaid Bid with or without notice to us shall in any manner discharge or otherwise, however, affect this guarantee and our liabilities and commitments hereunder.
4. The guarantee shall be binding on us and our successors in interest and shall be irrevocable.
5. This guarantee shall remain valid upto _____.

Yours faithfully,

Note: Any extensions / amendments (in all guarantees/bonds) if required shall be made on stamp papers of Rs.50

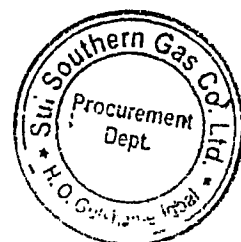

(On Stamp Paper @ Rs.100 for first Rs.100, 000 and Rs.50 per subsequent Rs.100, 000 of Guarantee Value)

PERFORMANCE BOND FORMAT

Sui Southern Gas Company Limited,
ST-4/B, Sir Shah Muhammad Suleman Road,
Block 14, Gulshan-e-Iqbal,
Karachi.

Bank Guarantee #
Date of Issue :
Date of Expiry :
Amount :

Tender Enquiry No SSGC / SC /

Dear Sirs,

In consideration of your entering/having entered into Contract No. _____ with M/s. _____ hereinafter called "The Contractor" and in consideration of value received from the Contractor, we hereby agree and undertake as follows:-

1. To make un-conditional payment of Rupees _____ and un-conditional payment in such amount as you may require from time to time as and when called upon by you to do so, not exceeding in the aggregate payment of Rupees _____, being the amount covering liquidated damages and security for the due fulfillment by the Contractor of all liabilities, obligations, commitments and total and faithful performance of the above Contract by the Contractor as specified in the above mentioned Contract upon your written demand(s) without further recourse, question or reference to the Contractor or any other person in the event of the Contractor's default in compliance with its obligations, liabilities and faithful performance arising under and in pursuance of the Work committed by it in the above mentioned agreement of which you shall be the sole judge.
2. To accept written intimation(s) from you as sufficient evidence of the existence of default or non compliance as aforesaid on the part of the Contractor and to make payment immediately upon receipt of the written intimation.
3. To keep this guarantee in full force from the date of this guarantee till the Contractor's obligations as specified in the above referred Contract and all other obligations of the Contractor as are contained in the above contract are duly fulfilled by the Contractor to the satisfaction of the Company.
4. No grant of time or other indulgence to, or composition, or arrangement with the Contractor in respect of the performance of its obligations under and in pursuance of the said agreement or any clause thereof, with or without notice to us shall in any manner discharge or otherwise howsoever effect this guarantee and our liabilities and commitment there under.
5. The guarantee shall be binding on us and our successors in interest and shall be irrevocable.
6. This guarantee shall not be affected by any change in the constitution of the guarantor bank or the constitution of _____.
6. This guarantee shall remain valid upto _____.

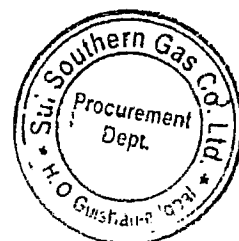

DECLARATION FORM

(FORMAT OF DECLARATION)

M/s. _____ [the Seller/Supplier] hereby declares its intention not to obtain or induce the procurement of any contract, right, interest, privilege or other obligation or benefit from Sui Southern Gas Company Limited or any administrative subdivision or agency thereof or any other entity owned or controlled by Sui Southern Gas Company Limited (SSGCL) through any corrupt business practice.

Without limiting the generality of the foregoing, [the Seller/Supplier] represents and warrants that it has fully declared the brokerage, commission, fees, etc., paid or payable to anyone and not given or agreed to give and shall not give or agree to give to anyone within or outside Pakistan either directly or indirectly through any natural or juridical person, including its affiliate, agent, associate, broker, consultant, director, promoter, shareholder, sponsor or subsidiary, any commission, gratification, bribe, finder's fee or kickback, whether described as consultation fee or otherwise, with the object of obtaining or inducing the procurement of a contract, right, interest, privilege or other obligation or benefit in whatsoever form from SSGCL, except that which has been expressly declared pursuant hereto.

[The Seller/Supplier] certifies that it has made and will make full disclosure of all agreements and arrangements with all persons in respect of or related to the transaction with SSGCL and has not taken any action or will not take any action to circumvent the above declaration, representation or warranty.

[The Seller/Supplier] accepts full responsibility and strict liability for making any false declaration, not making full disclosure, misrepresenting facts or taking any action likely to defeat the purpose of this declaration, representation and warranty. It agrees that any contract, right, interest, privilege or other obligation or benefit obtained or procured as aforesaid shall, without prejudice to any other rights and remedies available to SSGCL under any law, contract or other instrument, be voidable at the option of SSGCL.

Notwithstanding any rights and remedies exercised by SSGCL in this regard, [the Seller/Supplier] agrees to indemnify SSGCL for any loss or damage incurred by it on account of its corrupt business practices and further pay compensation to SSGCL in an amount equivalent to ten times the sum of any commission, gratification, bribe, finder's fee or kickback given by [the Seller/Supplier] as aforesaid for the purpose of obtaining or inducing the procurement of any contract, right, interest, privilege or other obligation or benefit in whatsoever form of SSGCL.

SIGNATURE & STAMP

NOTE

1. The above declaration is to be furnished along with the bid on letter head, for bid(s) amounting to total bid value of Rs. 10,000,000/- (Ten million) or above.
2. Please note that submitting the declaration is a mandatory requirement.

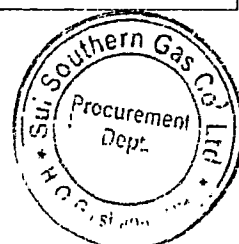

CONTRACT FORM

Contract No. SSGC/SC/

ARTICLES OF AGREEMENT

THIS AGREEMENT, made and entered into this _____ day of _____, 2018 by and between Sui Southern Gas Company Limited, having its office at ST-4/B, Sir Shah Muhammad Suleman Road, Block 14, Gulshan-e-Iqbal, Karachi, hereinafter referred to as the "Company" of the one part and M/s. _____ hereinafter referred to as the "Contractor", (which expression shall include the successors, of the said firm, heirs, executives, administrators and assigns of the Partners of the said firm individually or severally) of the other part.

WITNESSETH:

WHEREAS, under the procedures, bids have heretofore been received by the Company for carrying out "_____ work and the tender of the Contractor for the said work has been accepted by the Company.

NOW THEREFORE, for and in consideration of the promises, negotiations, covenants and agreements hereunder contained and to be performed by the parties hereto, the said parties hereby covenant and agree as follows:-

Article-1 Work and Cost of the Work:

- i) In consideration of the covenants and agreements to be kept and performed by the contractor and for the faithful performance of this Contract and the completion of the work embraced therein according to the specifications and conditions herein contained and referred to or agreed to in course of subsequent negotiations and in accordance with the Contract, the Company shall pay and the Contractor shall receive and accept as full compensation for everything furnish and done by the contractor under this agreement as sum of approximately Rs. _____, or such other sums as may be ascertained in accordance with the conditions of Contract, etc. and at rates quoted against each item of work and agreed to and accepted by the parties as one instrument, and at the times and in the manner prescribed by the conditions of the Contract.
- ii) The Contractor at his own proper cost and expense shall do all work and furnish all labour, materials, tools, supplies, machinery and other equipment and plant that may be necessary for the satisfactory completion of all the works as set forth in the contract documents.

Article-2 - Time:

The maintenance of a rate of progress in the works at a rate which will result in its completion within the specified time, is of the essence of the contract and the Contractor agrees to proceed with all the due diligence and care at all times to take all precautions to ensure the timely completion as defined herein; time being deemed to be essence of the Contract of part of the Contractor.

The said work shall be started on the Contractor's receipt from the Company of a written order to proceed, and the Contractor shall have the work called for duly and fully complete in total _____ months {including _____ () weeks mobilization period} from the date of issuance of such order.

Article-3 - Contract Documents:

It is understood and agreed that the contract documents which comprise this Contract are attached hereto and made a part hereof and consist of the following :-

- a) The Article of Agreement.

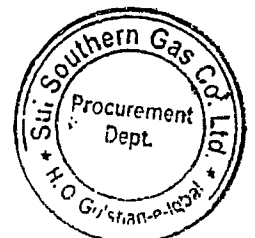

- b) Bid ((submitted vide letter No. _____, dated _____ comprising Letter of Invitation, Instructions to bidders, Scope of Work, Special and General Conditions of Contract, Tender Form, Bill of Quantities, Drawings, etc.).
- c) Company letter No. _____, dated _____.
Contractor letter No. _____, dated _____.
- d) Notice of Award (Letter of Intent (LOI) No.SSGC/MAT/S&C/_____, dated _____.
- e) Acceptance by the Contractor on the copy of LOI.
- f) Letter to Proceed No.SSGC/PROC/S&C/_____, dated _____.
- g) Performance Bank Guarantee No. _____, dated _____, amounting to Rs. _____ issued by M/s. _____.

It is agreed by the parties to the contract that this contract shall be executed in two counterparts; one copy to be retained in the office of the Sui Southern Gas Company Limited and one given to the Contractor.

IN WITNESS WHEREOF the parties hereto have executed this Contract at Karachi in two counterparts by their duly authorized representatives as of the day and year herein above set forth.

Signed for and on behalf of
M/s. Sui Southern Gas Company Limited

Signed for and on behalf of
M/s. _____ Karachi

Signature : _____

Signature : _____

Name : _____

Name : _____

In the presence of :

Signature : _____

Signature : _____

Name : _____

Name : _____

Signature : _____

Name : _____

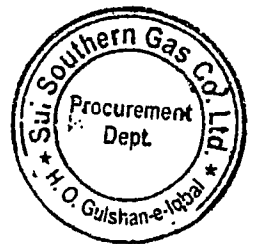

Supplier code: _____

FORM-X

BANK ACCOUNT DETAILS

(Mandatory requirement for Digital Online Banking)

As per FBR Regulations ref # C.No.4 (24) IT-Budget/2021-142150-R dated 23rd Sept'2021 to make the payment online w.e.f. 01-11-2021. All beneficiaries are required to fill in the below details, which is mandatory:

Name of Firm: _____

Address of Firm: _____

CNIC #: _____

NTN #: _____

Bank Name: _____

A/C Title name: _____

Branch code: _____

Bank A/c #: _____ (16 Digits)

Bank IBAN #: _____ (24 Digits)

Information already submitted.

Authorized Sign & Stamp

Date: _____

Note: All payments transactions will be made on above mentioned Account details. This is only a one time information to be provided by the all beneficiaries. Incase if the above detail has already submitted, please tick the box above "Information already submitted" and also ensure Form-X is duly signed & stamped.

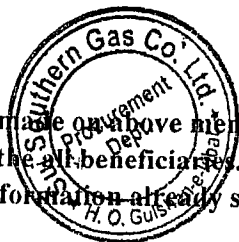

ANNEXURE: I

Declaration of Ultimate Beneficial Owners Information for Public Procurement Contracts.

1. Name
2. Father's Name/Spouse's Name
3. CNIC / NICOP/Passport No.
4. Nationality
5. Residential address
6. Email address
7. Date on which shareholding, control or interest acquired in the business.
8. In case of indirect shareholding, control or interest being exercised through intermediary companies, entries or other legal persons or legal arrangements in the chain of ownership or control, following additional particulars to be provided:

1	2	3	4	5	6	7	8	9	10
Name	Legal form (Company/Limited Liability Partnership /Association of Persons/Single Member Company/Partnership Firm/Trusted/Any other Individual, Body Corporate (to be Specified)	Date of Incorporation / Registration	Name of Registering Authority	Business Address	Country	Email Address	Percentage of shareholding control or interest of BO in the Legal Person or Legal Arrangement	Percentage of shareholding, Control or Interest of Legal Person or Legal Arrangement in the Company	Identity of Natural Person who Ultimately owns or Controls the Legal Person or Arrangement

9. Information about the Board of Directors (details shall be provided regarding number of shares in the capital of the company as set opposite respective names).

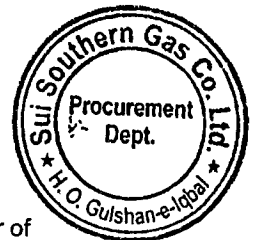

1	2	3	4	5	6	7	8
Name and surname (in block Letter's)	CNIC no (in case of foreigner Passport No)	Father's / Husband's Name in Full	Current Nationally	Any other Nationality lies)	Occupation	Residenti ally address in full of the registered / principle office address for a subscribe rs other that natural Person	Numbers of shares taken by cash subscribers (in figures and words
			Total numbers of shares taken (in figures and words)				

10. Any other information incidental to or relevant to beneficial owner(s).

Name and signature
(Person authorized to issue notice on behalf of the company)

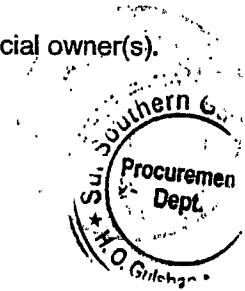

Form of Bid-Securing Declaration

[The Bidder shall fill in this Form in accordance with the instructions indicated.]

Date: [date (as day, month and year)]

No.: [number of Bidding process]

Alternative No.: [insert identification No if this is a Bid for an alternative]

To: [complete name of Procuring Agency]

We, the undersigned, declare that

We understand that, according to your conditions, Bids must be supported by a Bid-Securing Declaration.

We accept that we will be blacklisted and henceforth cross debarred for participating in respective category of public procurement proceedings for a period of (not more than) six months, if fail to abide with a bid securing declaration, however without indulging in corrupt and fraudulent practices, if we are in breach of our obligation(s) under the Bid conditions, because we:

- (a) have withdrawn our Bid during the period of Bid validity specified in the Letter of Bid; or
- (b) having been notified of the acceptance of our Bid by the Procuring Agency during the period of Bid validity; (i) fail or refuse to sign the Contract; or (ii) fail or refuse to furnish the Performance Security (or guarantee), if required, in accordance with the ITB.

We understand this Bid Securing Declaration shall expire if we are not the successful Bidder, upon the earlier of (i) our receipt of your notification to us of the name of the successful Bidder; or (ii) twenty-eight days after the expiration of our Bid.

Name of the Bidder: _____

Name of the person duly authorized to sign the Bid on behalf of the Bidder: _____

Title of the person signing the Bid: _____

Signature of the person named above: _____

Date signed: _____ day of _____

*: In the case of the Bid submitted by joint venture specify the name of the Joint Venture as Bidder

** Person signing the Bid shall have the power of attorney given by the Bidder attached to the Bid

[Note: In case of a Joint Venture, the Bid-Securing Declaration must be in the name of all members to the Joint Venture that submits the Bid.]

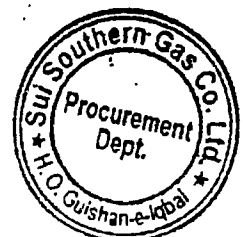

**SUI SOUTHERN GAS COMPANY LIMITED
PROCUREMENT DEPARTMENT**

BLACKLISTING MECHANISM
(REVISION-1)

1 BACKGROUND

In pursuance of Rule-19 of Public Procurement Rules, 2004 read with Rule-2(f) (fa) and the criteria for Blacklisting of Suppliers and Contractors / Consultants doing business with the SSGCs is reiterated hereafter to eliminate unfair trade practices.

2 SCOPE

The procedure shall be applicable and remain in force, along with any amendments thereto, within Sui Southern Gas Company Limited ("SSGC") until any clear instructions or guidelines are impacted by the Government through Public Procurement Regulation Authority (PPRA), Pakistan Engineering Council (PEC), or any other competent forum. The procedure shall also be applicable on the pre-qualified firms. The procedure shall be applicable on any "Person(s) / Firm(s)", which for the purposes of this Mechanism shall inter alia include suppliers, bidders, contractors, consultants, firms, individuals, and organizations transacting business with SSGC. Wherever any provision of this Mechanism shall be in conflict with provisions of any applicable guidelines of donor agencies, or any other applicable Statute / Law or Rule enforced at the time in Pakistan, the provisions of such applicable guidelines, laws, or rules shall prevail. This SOP shall become a part of the future Bidding Documents.

3 DEFINITION OF TERMS

- 3.1 "Appellate Authority" - Authority to Appeal against issuance of Blacklisting Order.
- 3.2 "Appeal" - Right of firm/individual to lodge protest against the issuance of Blacklisting Order.
- 3.3 "Procuring Agency" - Any department/division/factory/project exercising general and/or administrative control over the unit.
- 3.4 "Blacklisting Order" - An administrative penalty disqualifying a firm/individual from participating in procurement for a given period.
- 3.5 "Suspension" - The administrative penalty imposed for infractions committed during the competitive bidding stage, whereby such firms/individuals are prohibited from further participation in the bidding process of Procuring Agency.
- 3.6 "Contract Implementation" - A process of undertaking a project or contract in accordance with the contract documents.
- 3.7 "Termination of Contract" - Extinction of contract by reason or resolution or rescission under applicable rules/regulations/laws arising from the default of the firms/individuals.
- 3.8 "Delist" - Removal of supplier/contractor from blacklisting.
- 3.9 "PA-Project Authority" - A three-member committee comprising of User, HSE&QA & Procurement Deptt. to address the issue.
- 3.10 RPC-SSG's Rights Protection Committee - To examine the justification of PC.

Page 1 of 10

Dated : 12th October 2020

Revision-1 : Dt: 3 Sept 2024



4. REASONS FOR BLACKLISTING

4.1 The following shall comprise the broad multilateral guidelines for blacklisting:

4.1.1 "Corrupt Practice" means the offering, giving, receiving, or soliciting, directly or indirectly, of anything of value to influence the action of a public official in the procurement process or in contract execution;

4.1.2 "Fraudulent Practice" means a misrepresentation or omission of facts in order to influence a procurement process or the execution of a contract;

4.1.3 "Collusive Practice" means a scheme or arrangement between two or more bidders, with or without the knowledge of the Purchaser, designed to establish bid price at artificial, non-competitive levels, and

4.1.4 "Coercive Practice" means harming or threatening to harm, directly or indirectly, Person(s) / Firm(s) or their property to influence their participation in the procurement process or affect the execution of a contract.

4.2 In addition to above, blacklisting of firms/individuals may be resorted to when the charges are of serious nature, which include but are not limited to the following:

4.2.1 Competitive Bidding Stage

During the competitive bidding stage, the Procuring Agency shall impose on bidders or prospective bidders the penalty of Suspension from participating in the public bidding process, without prejudice to the imposition of additional administrative sanctions as the internal rules of the agency may provide and/or further criminal prosecution, as provided by applicable laws, for violations committed which include but are not limited to the following:

- i. Submission of eligibility requirements containing false information or falsified documents.
- ii. Submission of bids that contain false information or falsified documents, or the concealment of such information in the bids in order to influence the outcome of eligibility screening or any other stage of the public bidding.
- iii. Submission of unauthorized or fake documents for pre-qualification/ tendering i.e. without specific authorization from the principals/ manufacturers etc.
- iv. Failure of the firm to provide authentic Warranty Undertaking and Performa Invoice of the manufacturers / Principal / Trading house.
- v. Failure of the firm to submit specific authority letter of the Original Equipment Manufacturer (OEM) for participation in a particular tender;
- vi. ~~Unauthorized use of one's name, or using the name of another for~~ purpose of public bidding.
- vii. Deviations from specifications and terms & conditions of the purchase order/contract.
- viii. Withdrawal of a bid, or refusal to accept an award or refusal to perform the job or enter into contract with the government without justifiable cause, after he had been adjudged as having submitted the Lowest Calculated Responsive Bid or Highest Rated Responsive Bid.
- ix. Refusal or failure to post the required performance security within the prescribed time.
- x. Refusal to clarify or validate in writing its Bid during post qualification within a period of seven (7) working days, or as may be specifically prescribed, from receipt of the request for clarification.

Page 2 of 10
Dated : 12th October 2020
Revision-1 : Dt: 3 Sept 2024



- xi. Any documented unsolicited attempt by a bidder to unduly influence the outcome of the bidding in his favor.
- xii. Any attempt to give illegal gratification to any representative of the purchaser to influence the process of procurement.

In addition to the penalty of suspension, the bid security posted by the concerned bidder or prospective bidder could also be forfeited / encashed.

4.2.2 Purchase Order / Contract Implementation Stage

During the Purchase Order / Contract implementation stage, the procuring entity shall impose on contractors after the termination of the contract the penalty of suspension from participating in the public bidding process, without prejudice to the imposition of additional administrative sanctions as the internal rules of the agency may provide and/or further criminal prosecution, as provided by applicable laws, for violations committed which include but are not limited to the following:

- i. Failure of the contractor, due solely to his fault or negligence, to mobilize and start work or performance within the specified period in the Letter to Proceed.
- ii. Failure by the contractor to fully and faithfully comply with its contractual obligations without valid cause, or failure by the contractor to comply with any written lawful instruction of the Procuring Agency or its representative(s) pursuant to the implementation of the contract. For the procurement of infrastructure projects or consultancy contracts, lawful instructions include but are not limited to the following:
 - a. Employment of competent technical Person(s) / Firm(s)nel, competent engineers and/or work supervisors;
 - b. Provision of warning signs and barricades in accordance with approved plans and specifications and contract provisions;
 - c. Stockpiling in proper places of all materials and removal from the project site of waste and excess materials, including broken pavement and excavated debris in accordance with approved plans and specifications and contract provisions;
 - d. Deployment of committed equipment, facilities, support staff and manpower; and
 - e. Renewal of the effectivity dates of the performance security after its expiration during the course of contract implementation.
 - f. Non-Performance of the supplier in respect of tender terms & conditions and the delivery / supply of material.
- iii. Assignment and subcontracting of the contract or any part thereof or substitution of key Person(s) / Firm(s)nel named in the proposal without prior written approval by the Procuring Agency.
- iv. For the procurement of goods, unsatisfactory progress in the delivery of the goods by the manufacturer, supplier or distributor arising from his fault or negligence and/or unsatisfactory or inferior quality of goods, as may be provided in the contract.
- v. For the procurement of consulting services, poor performance by the consultant of his services arising from his fault or negligence, any of the following acts by the consultant shall be construed as poor performance:
 - a. Defective design resulting in substantial corrective works in design and/or construction;
 - b. Failure to deliver critical outputs due to consultant's fault or negligence;
 - c. Specifying materials which are inappropriate, substandard or way above acceptable standards;



- d. Allowing defective workmanship or works by the contractor being supervised by the consultant; and
 - e. Submitting CV's of key Person(s) / Firm(s) in the prequalifying process or bid documents of professionals that are not in actual employment of the bidder.
- vi. For the procurement of infrastructure projects, poor performance by the contractor or unsatisfactory quality and/or progress of works arising from his fault or negligence.
 - vii. Willful or deliberate abandonment or non-performance of the project or contract by the contractor resulting to substantial breach thereof without lawful and/or just cause.

In addition to the penalty of suspension, the performance security posted by the contractor could also be forfeited.

4.2.3 In addition to above, other grounds for blacklisting of firms/individuals include but are not limited to the following:

- i. Obtaining fraudulent payments;
- ii. Obtaining contracts by misleading the purchaser;
- iii. Refusal to pay SSGC dues etc.;
- iv. Failure to fulfill contractual obligations;
- v. Changes in the status of firm's ownership/partnership etc. causing dissolution of the firm which existed at the time of inspection / bidding prior to original registration of the firm;
- vi. Registration of a firm with a new name by the Proprietor or family or a nominee thereof of a firm that has been already blacklisted;
- vii. Consequential operational damages caused to SSGC equipment or infrastructure as a result of equipment or parts thereof supplied on trial basis or due to failure of such equipment;
- viii. Contractors who have negotiated Plea Bargain under the National Accountability Ordinance 1999, or contractors involved with any other criminal proceedings conducted by any investigation agency where default has been proved specifically in relation to supplies made to or contracts concluded with SSGC.
- ix. Involved in litigation or needless petitioning to influence or obstruct the procurement process either on his own behalf or at the behest of any other vested interest;
- x. A firm may be disqualified for a period extendable to two years in case a decision by a court is awarded against the said firm after litigation, or where the firm is involved in litigation at least three times during two financial years, or where a firm has on account of litigation caused substantial financial losses to SSGC;
- xi. Blacklisted by other Federal and Provincial Government Ministries / Divisions / Departments and organizations / autonomous bodies subordinate thereto; and
- xii. Blacklisting in case of Joint Venture firms will also result in termination of the concerned Joint Ventures Partners.

5. SYSTEM OF PENALTIES

For the purpose of uniformity, following system of penalties shall be adopted for procurement of goods, works and services:

- 5.1 Blacklisted and henceforth cross debarred for participation in any public procurement or disposal proceedings for the period of not more than ten years, if corrupt and fraudulent

Page 4 of 10
Dated : 12th October 2020
Revision-1 : Dt: 3 Sept 2024

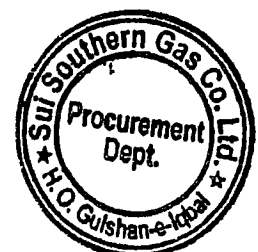

practice as defined in these rules is established against the bidder or the bidders in pursuance of blacklisting proceedings;

- 5.2 blacklisted and henceforth cross debarred for participation in respective category of public procurement or disposal proceedings for a period of not more than three years, if the bidder fails to perform his contractual obligations during the execution of contract or breaches the contract due to his capacity and capability to perform or otherwise. However, procuring agency shall initiate such blacklisting or debarment proceedings after exhausting the forum of arbitration, provided that such provision exists in the conditions of contract, and if such failure or breach is covered in the respective dispute settlement clauses of the contract, and
- 5.3 blacklisted and henceforth cross debarred for participation in respective category of public procurement or disposal proceedings for a period of not more than six months, if the bidder fails to abide with a bid securing declaration, however without being indulged in any corrupt and fraudulent practice.

6. SUSPENSION AND BLACKLISTING PROCEDURE

1. The supplier or contractor who is to be blacklisted for a specified period is given adequate opportunity of being heard.
2. The supplier or contractor who is to be blacklisted for a specified period is called for meeting by providing adequate time, so as to given him adequate opportunity of being heard before taking any action.
3. In case the supplier or contractor does not attend the meeting on the given date and time a final notice is served to him / her to attend the meeting on the revised date and time. Despite the final notice, if the supplier or contractor does not attend the meeting as per schedule, automatically be considered at fault. Action will be taken as per below clauses 5 to 9.
4. A three-member committee will form comprising of User, Procurement and HSE&QA departments to address the issues in the meeting with the supplier or contractor. Members of committee may not below of grade IV.
5. In case the supplier or contractor is found at default based on the fact of the case as well as the tender terms and conditions, and do not justify the grounds of his default as per the tender terms and conditions, the approval is sought from the management for their temporary or permeanant blacklisting alongwith encashment of bid bond or PBG as the case may be.
6. The decision of the management is communicated to the defaulted supplier or contractor through a formal letter.
7. A copy of the letter of the defaulted supplier / contractor alongwith covering letter with pertinent documents is / also forwarded to the Authority (PPRA) for uploading on PPRA website.
8. The blacklisting information of the supplier / contractor is uploaded on the websites.

Page 5 of 10
Dated : 12th October 2020
Revision-1 : Dt: 3 Sept 2024



9. Any bidder not satisfied with the decision of the procuring agency, may lodge an appeal in the relevant court of jurisdiction.
10. After coming into force the procurement contracts, the dispute between the parties to the contract shall be settled by arbitration.

7. STATUS OF BLACKLISTED FIRM/INDIVIDUAL

Blacklisting of a firm/individual will not affect other ongoing contracts/works/supply orders. However, such blacklisted firm shall stand barred from all future tender processes/participation and Standing Security, if any, could be confiscated until recovery of financial damages ascertained by the authority while issuing Blacklisting Order.

8. DELISTING

A temporary blacklisted firm / individual shall be automatically restored after the period for the penalty has elapsed, unless the procuring agency wants to maintain the blacklisted status of firm / individual due to justifiable reasons with the prior approval of Appellate Authority. In the latter case, the temporary blacklisted firm / individual shall be restored.

9. AMENDMENTS

9.1 In the implementation of Blacklisting Mechanism, the modifications may be introduced thereto through the amendment of its specific provisions as the need arises.

9.2 Any amendment to this Blacklisting Mechanism shall be applicable to tenders advertised for bid after the effectivity of the said amendment.

10. EFFECTIVITY

The Blacklisting Mechanism or any amendments thereof shall take effect immediately and from the date of its issuance. All future tender documents must be governed by these instructions. However, these cannot override the provisions of Public Procurement Rules, 2004.

11. The Steps to be Followed are As Under

The causes and reasons to be taken into consideration for Debarment / Blacklisting of any Person(s) / Firm(s) are given as under:

1. PRE-AWARD STAGE:

The following shall be considered, inter alia, the events / reasons for initiating proceedings under this Mechanism at the Pre-Award Stage:

- i Indulging in Corrupt: Fraudulent as well as Collusive practices.
- ii Submission of false and spurious documents, making false statements, making frivolous complaints and allegations to gain undue advantage.

Page 6 of 10
Dated : 12th October 2020
Revision-1 : Dt: 3 Sept 2024

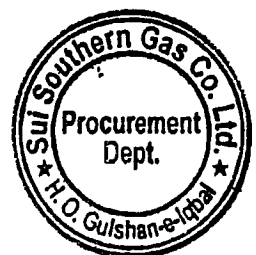

- iii Commission of embezzlement, criminal breach of trust, theft, cheating, forgery, bribery, falsification or destruction of records, receiving stolen property, false use of trademark, securing fraudulent registration, giving false evidence, furnishing of false information of serious nature.
- iv Submission of false bid security or infringement of documents to get undue monetary or any other benefit.
- v Breach of confidentiality of evaluation process based on illegal access or in any way to get undue benefit or to provide benefit or to frustrate the bidding/evaluation process. This will also include attempts to sabotage the bidding process directly or indirectly.

2. POST- AWARD STAGE:

The following shall be considered, interalia, the events / reasons for initiating proceedings under this Mechanism at the Post-Award Stage:-

- i. Extraordinary delay in signing or refusal to accept the Notification of Award and/or the contract without any cogent reason.
- ii. Misconduct, i.e., failure to proceed with the signed contract, withdrawal of commitments, quoting an unreasonably and unfairly low financial offer and subsequently withdrawing such an offer, frustrating the evaluation/bidding process and not responding to written communication in a reasonable time.
- iii. Causes mentioned in Sub-Clauses i, ii and iii above.
- iv. Submission of fake / frivolous or mutilated Performance Guarantee or Advance Payment Guarantee etc.
- v. Non-satisfactory performance during the execution of the contract / purchase order.
- vi. Non-performance or Breach of provisions / clauses of the contract agreements/tender terms.
- vii. Notwithstanding the warranty/defect liability period, any defect in a product, equipment, plant, facility or services rendered that may subsequently surface during field operations within 5 years of its commissioning.
- viii. Failure to honour obligations within warranty period or defect liability period as defined in the contract.

3. OTHER CAUSES :

- i. The Person(s) / Firm(s) is blacklisted by any Government department in Pakistan, or it is established that the firm is involved in any kind of corruption or corrupt practices anywhere in the world.
- ii. Violations of provisions / instructions set down in the Bidding Documents.

Page 7 of 10
Dated : 12th October 2020
Revision-1 : Dt: 3 Sept 2024

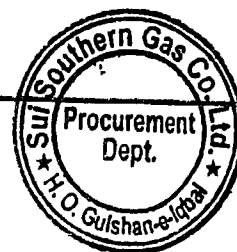

- iii. Any attempt / activity to malign or bring SSGC into disrepute and harm its interest(s).
- iv. Person(s) / Firm(s) blacklisted by International Financial Institutions (donor agencies) will be liable to be blacklisted after receipt of confirmation from the donor agencies without any further proceeding.
- v. Any other cause deemed just and appropriate by CPPA in the given circumstances.

Note: (1) If above mentioned causes occur either on part of the principal bidder or the local agent, both shall be considered for blacklisting / debarment.

- (2) The authorization of the foreign bidder to local agent shall contain his complete particulars including the name of the company, name of the owner, National Tax number (NTN), CNIC (Computerized National Identity Card) No. etc. In case, the said information is found to be missing, even after calling for the same within a reasonable time, the authority letter shall not be accepted.
 - (3) The Bidding Documents shall be issued against original authority letter or in case of scanned copy, the email of the foreign bidder shall be enclosed. However, at the time of bidding, the original authority letter shall be attached with the bid. In the absence of the same, the bid shall be rejected.
4. FORMULATION of SSGC's Rights Protection Committee: A permanent Committee namely "SSGC's Rights Protection Committee (RPC or Committee)" shall examine the justification of the reasons given by the Project Authority prior to blacklisting. Member of RPC must be one grade up from the members of PA.

5. PROCEDURE FOR BLACKLISTING

Upon receipt of or obtaining information and/or knowledge that any Person(s) / Firm(s) is involved in practices mentioned in hereinabove under the heading of Pre-Award Stage; Post-Award Stage and Other Causes, the concerned Project Authority / formation shall promptly formulate its recommendations and submit through the Managing Director, SSGC to SSGC's RPC / Committee along with its findings, details of charges and documentary evidences to initiate proceedings under this Mechanism.

6. INITIATION OF AN ACTION

- (i) Within a period of 15 days after receiving the recommendations of Blacklisting / Debarment from the concerned Project Authority, the Convener of the Committee shall issue a Show Cause Notice ("Notice") thereby informing the Person(s) / Firm(s) about the alleged charges and shall provide an opportunity to the defend said charges within a time period of 15 (fifteen) days.
- (ii) The Person(s) / Firm(s) shall be accorded adequate opportunity of hearing in order to defend the charges within the given timelines.
- (iii) The Notice to the Person(s) / Firm(s) shall be sent at the mailing/postal address as provided under the Contract or any other address provided by way of subsequent written communication by the Person(s) / Firm(s) The non-receipt of the Notice due to incorrect / change in mailing address without any written communication shall not be attributable to

Page 8 of 10
Dated: 12th October 2020
Revision-1 : Dt: 3 Sept 2024

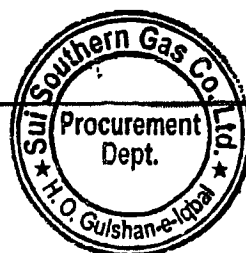

SSGC. In case of non-receipt of any reply from the accused Person(s) / Firm(s) within the formulated time, but not less than the time given in (i) above, the Committee shall have the right to proceed on Ex-parte basis.

7. DECISION

The committee shall hold an independent inquiry/investigation as the case may be, and, which may include site visits and interviews with the parties concerned. The Committee shall complete the entire inquiry/investigation, preferably within a period of 30 days after receipt of response from the Person(s) / Firm(s) against whom proceedings under this Mechanism has been initiated and shall present the report to the Managing Director, SSGC. If required, the Committee may report the case to an appropriate law enforcement agency depending upon the nature of the case for detailed investigations with the prior approval of Managing Director, SSGC. iii. The Person(s) / Firm(s) against whom proceedings have been initiated under this Mechanism shall not proceed for arbitration/litigation during the proceedings for blacklisting.

8. COMMUNICATION OF DECISION

After recommendation for temporary & permanent blacklisting by "SSGC's Rights Protection Committee (RPC)", the Person(s) / Firm(s) concerned shall be informed within 10 days of such decision. The decision of the Committee will be notified on SSGC 's and PPRA's websites and shall also be conveyed to Pakistan Engineering Council.

The temporary Blacklisting on the grounds and reasons specified herein above shall be for a reasonable specified period of time and as a general rule of prudence, the period may not exceed three years, except in cases where debarment/blacklisting has been done by any other government department or an International Financial Institution (Donor Agency). In case the Person(s) / Firm(s) has been blacklisted by the government department or the International Financial

Institution (donor agency), the period of temporary blacklisting/debarment shall be for a maximum period of 3 years or the time period for which the concerned government department/International Financial Institution (Donor Agency) debarred the contractor (whichever is higher). However the permanent blacklisting cannot be revived.

Action after the Person(s) / Firm(s) are placed on Blacklisting List:

- i. The decision of blacklisting will be immediately circulated to all concerned as mentioned herein above under the heading Communication of Decision.
- ii. In case of a contract already awarded to a Person(s) / Firm(s) which has been blacklisted and termination is either not possible or not feasible, the concerned Project Authority may proceed in this case to complete the contract with the approval of Competent Authority. (iii) The blacklisted Person(s) / Firm(s) shall stand disqualified from bidding from the date of decision against them. Any pending bids shall also stand rejected. If a contract has already been awarded to Person(s) / Firm(s), it shall be voidable at the option of SSGC. (iv) A separate register or data base will be maintained for blacklisted firms indicating reasons and period.

Page 9 of 10

Dated : 12th October 2020

Revision-1 : Dt: 3 Sept 2024

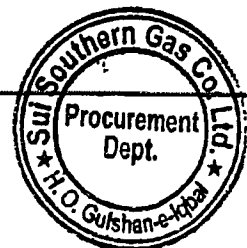

9. Effectiveness

This Mechanism or any amendments thereof shall take effect immediately with the approval from Managing Director of Sui Southern Gas Company Limited.

Page 10 of 10
Dated : 12th October 2020
Revision-1 : Dt: 3 Sept 2024

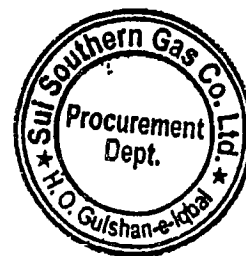



**Sui Southern Gas
Company Limited**
Health, Safety, Environment & Quality Assurance

HSE&QA AWARENESS FOR SUPPLIERS AND CONTRACTORS (Revised in 2023)



Always be proactive about safety!

Report Hazard before it results in an Accident

If it's UNSAFE!

- ✓ Report it
- ✓ Remove it
- ✓ Replace it

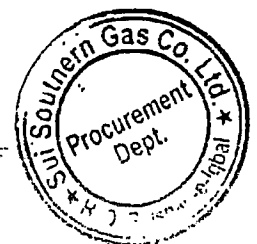

M.P.



 Sui Southern Gas Company Limited.

HSE & QA-IMS POLICY

SSGC is committed to the Health and Safety of all its Employees & Stakeholders, preservation of Environment and achieving Operational excellence by improving Quality of products / services along with efforts to promote Safety Culture in the Company. Continual improvement of HSE and QA performance by reducing potential hazards to prevent injuries and illness is our key priority. It also includes communication, consultation and participation on HSE and QA objectives and targets with stakeholders, conserving resources and adhering to applicable Laws and Regulations in all activities / processes related to the Transmission and Distribution of natural gas within its franchise area.

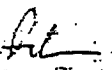
Managing Director
August, 2021.

MR

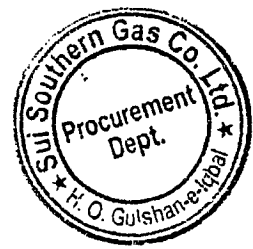

1. PURPOSE

The purpose of this procedure is to identify the context of the organization, assess the risks and opportunities and establish controls associated with all the activities undertaken by the company to address risks and opportunities for:

- a. SSGC existing facilities/installations.
- b. Any routine/non-routine activity, performed within permanent locations or outside permanent locations of SSGC, that requires prior permit/safety analysis to identify and mitigate safety risks.
- c. Any new project.
- d. Covering all the activities performed by SSGC taking into consideration of compliance, obligations, risks & opportunities within the scope, external and internal issues related to scope of operations, requirements, information, needs and expectations of relevant interested parties.
- e. Providing guidance to employees in relation to hazard identification, risk assessment and risk control in respective areas.
- f. Identification, control, monitoring and management of environmental aspects and assessment of its impacts.

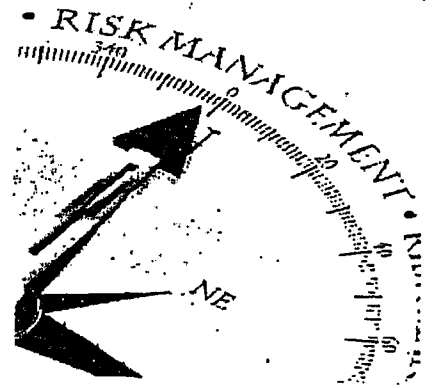

2. SCOPE

This procedure is applicable to the identification of occupational health and safety hazards and associated risks, environmental aspects and impacts associated with activities, processes and equipment related to SSGC existing facilities/installations, any new project or any routine/non-routine activity, performed within permanent locations or outside permanent locations of SSGC, that requires prior permit/safety analysis to identify and mitigate occupational health and safety risk.

3. DEFINITIONS & ACRONYMS

- a. **HAZARD:** Source or situation with a potential for harm in terms of injury or ill health, damage to property, damage to workplace environment, or a combination of these.
- b. **RISK:** Combination of probability of occurrence of a hazardous event or exposure and the resulting consequences.
- c. **OPPORTUNITY:** Opportunities can arise as a result of a situation favorable to achieving an intended result, for example, a set of circumstances that allow the organization to attract customers, develop new products and services, reduce waste or improve productivity. Actions to address opportunities can also include consideration of associated risks.
- d. **SWOT:** Strength, Weakness, Opportunity & Threat.
- e. **RISK MANAGEMENT:** The set of control measures used to reduce or eliminate specific risk.
- f. **RISK ASSESSMENT:** Risk Assessment is a systematic approach to hazard identification. This is the overall process of estimating the priority of risk and deciding significance of risk.
- g. **RISK ASSESSMENT METHODOLOGY:** Risk priority shall be defined by the risk assessment matrix. Hazards related to applicable legal requirements will fall in the high risk category.
- h. **HIRA:** Hazard Identification and Risk Assessment.
- i. **EAIA:** Environmental Aspect and Impact Assessment.
- j. **IEE:** Initial Environment Examination.
- k. **EIA:** Environment Impact Assessment.
- l. **ILL HEALTH:** Identifiable, adverse physical or mental condition arising from and/or made worse by a work activity and /or work related situation.
- m. **OHS&E:** Occupational Health, Safety & Environment.
- n. **PTW:** Permit to Work.
- o. **MOC:** Management of Change.
- p. **MOC Owner:** The employee who initiates the MOC.
- q. **JSA:** Job Safety Analysis.
- r. **EXECUTING DEPARTMENT:** It refers to the department performing the work or is responsible to get the work done through contractor.

MR

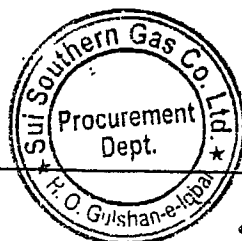

4. RESPONSIBILITIES

4.1 Corporate HSE&QA In-charge

- a. Managing OHS&E risks and their controls.
- b. Reporting to Senior Management on OHS&E related issues.
- c. Providing support to corporate HSE&QA team and zonal representatives.
- d. Liaise with zonal HSE team leaders/HSE&QA representatives for implementation of this procedure.

4.2 Zonal HSE team leaders

- a. Carrying out HIRA, providing and utilizing resources to identify and review OHS&E risks and implementing their controls in consultation with corporate HSE&QA team.
- b. Ensuring that employees, contractors and visitors have sufficient knowledge related to OHS&E.
- c. Maintaining records of the OHS&E with the help of local HSE&QA team.
- d. Implementing this procedure. Liaise with corporate HSE&QA team if required.

4.3 Zonal HSE&QA representative

- a. Coordinating with Zonal HSE team leader for carrying out HIRA and EAIA in their zones.
- b. Liaise with corporate HSE&QA team and zonal HSE team leader for OHS&E.
- c. Reviewing/monitoring HIRA and EAIA in their zones and providing input on any changes.

4.4 Departmental Head of Executing Department

Acquiring PTW for any activity that requires prior permit to identify and mitigate safety risks.
Ensure implementation of JSA for job/activity performed outside SSGC permanent locations.

4.5 Employees

Participating in the identification and assessment of OHS&E risks when required by either Zonal HSE team leader or HSE&QA representative.

4.6 Visitors & Contractors

Identifying and reporting any risk or hazard at any location of SSGC. This also includes the worksites and SSGC temporary locations during project executions.

5. DECISION MATRIX

Type of Risk/Hazard Assessment	Methodology	Responsibility
HIRA	Periodic risk assessment of SSGC's existing facilities/installations such as Head office, Headquarters, Regional offices etc.	Zonal HSE team leader
PTW	On-site Risk assessment (for Permanent Locations) for any routine/non-routine activity that requires prior permit to identify and mitigate safety risks.	Departmental head/Contractor executing the task/activity requiring PTW
JSA	On-site Risk assessment (for Field Locations) for any routine/non-routine activity.	Departmental head/Contractor executing the field activity

MR

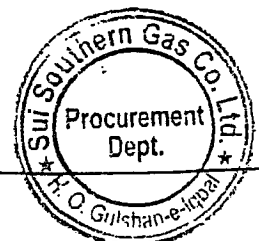

MOC	Risk assessments for new Projects, major changes or modifications in existing designs and infrastructure.	MOC owner
------------	---	-----------

Risk Assessment and Management Procedure is divided into five sections based on the type of risk assessment needed:

- Section 1: Context of the Organization.
- Section 2: Hazard Identification and Risk Assessment.
- Section 3: Permit to Work.
- Section 4: Job Safety Analysis.
- Section 5: Management of Change.

6. PROCEDURE

Section 1 Context of the Organization

6.1. Context of the Organization

- i. Management defines scope of the company services and its boundaries considering the internal and external issues of the organization.
- ii. In consultation with HSE&QA, Management & Zonal Heads identify external & internal interested parties and maintain its list with needs & expectations. Interested parties are those stakeholders who receive company services, who may be impacted by them, or those parties who may otherwise have a significant interest in the company. Interested parties may include:

Interested Parties	Requirements
Board of Directors	Good financial performance, legal compliance/avoidance of fines.
Law Enforcers/Regulators	Identification of applicable statutory and regulatory requirements for the products and services provided and understanding of the requirements.
Customers	Value for money, quality service, facilitation and quick response.
Bank/Finance	Good Financial Performance.
Employees	Professional development, prompt payment, health and safety, work/life balance, employment security.
Insurance	No claims/prompt payment/risk management.
Community	No complaint relating to: noise, parking, health and safety, pollution, waste.
External providers (Vendors/Suppliers)	Prompt payment as per agreed terms, health and safety, long-term working relationship.
Trade Unions	Compliance of local labor laws.

MR

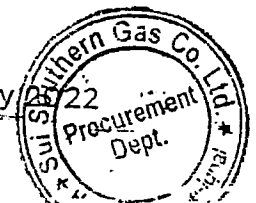
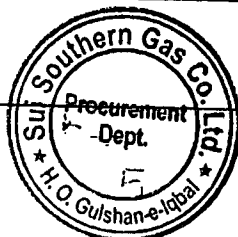

- iii. By using SWOT analysis or any other tool, identify external and internal issues that are relevant to company operations and its strategic direction and that may affect the ability to achieve the intended result(s) of integrated management system. Internal and external issues can be positive or negative that can affect the OH&S management system.

6.1.1. Internal issues could include in risk & opportunity assessments, but are not limited to:

- a. Operations spread in two provinces.
- b. Complex transmission and distribution network.
- c. Succession planning.
- d. Contractual relationships.
- e. Availability of reliable, qualified and competent workforce.
- f. Staff retention.
- g. Impact of unionization.

6.1.2. External issues could include in risk & opportunity assessments, but are not limited to:

- a. **Political:** Government policies, political stability, international trade agreements etc.
- b. **Economic:** Fuel/utility prices, cash flow, credit availability, exchange rates, tariffs and inflation, general taxation issues etc.
- c. **Social:** Consumer buying pattern, education level, advertising and publicity, ethical & religious issues, demographics etc.
- d. **Technological:** Intellectual property issues, software changes, internet, technology legislation, associated/dependent technology, renewable energy etc.
- e. **Legal and regulatory:** Consumer protection, industry-specific regulation and permits, trade union regulations, employment law, international legislation, human rights/ethical issues etc.
- f. **Environment:** Customer demographics and environmental issues.
- g. **Government:** The directives from Prime Minister, Ministry of Petroleum (energy division), regulatory bodies like OGRA, SEPA & BEPA etc.
- d. Ensuring the policy and objectives are established for the integrated management system and are compatible with the context and strategic direction of the organization.
- e. The management shall monitor and review information about these external and internal issues during the management review meetings.

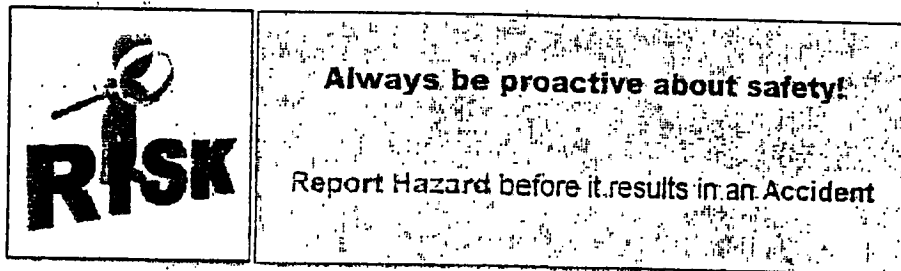

MR

Section 2 Hazard Identification and Risk Assessment

i. Hazard Identification and Risk Assessment

The Zonal HSE team leader in consultation with local HSE&QA representatives plan and initiate the HIRA and EAIA process. The assigned team must be competent and have enough knowledge of the entire process. Cross functional teams are recommended for such activity to cover all aspects during assessment. The record of OHS&E risk assessment is maintained in Hazard Identification & Risk Assessment Form (SSGC-IMS/CRM-F-01). The identification/assessment process shall take into account

- a. Routine & non routine activities, any emergency situations.
- b. Activities of all persons having access to the SSGC permanent and temporary locations.
- c. Human behavior, capabilities and other human factors.
- d. Designing of work processes.
- e. Material in use.
- f. Infrastructure, equipment and materials at the workplace or project site, whether provided by organization or others.
- g. Changes or proposed changes in the organization, its activities or materials.
- h. Fabrication, installation & commissioning.
- i. Handling & disposal of waste material.
- j. Purchase of goods & services.
- k. Any applicable legal obligations that is related to risk assessment and implementation of necessary controls.
- l. Before commencement of any new operation/activity.
- m. Periodic Review for updating the existing hazard identification and risk assessment information.

At SSGC, we adapt five steps of risk assessment:

- Step 1: Identify the hazards.
- Step 2: Decide who might be harmed and how.
- Step 3: Evaluate the risks and decide on precautions.
- Step 4: Record your findings and implement them.
- Step 5: Review your risk assessment and update if necessary.

ii. Risk Assessment Matrix

Risk assessment should be carried out as per assessment matrix below:

Risk Priority		Probability			
		Very Likely	Likely	Unlikely	Very Unlikely
Consequences	Catastrophic				Medium
	Significant			Medium	Medium
	Harmful		Medium	Medium	
	Negligible	Medium	Medium		

MR

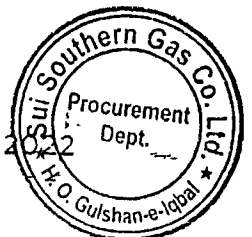
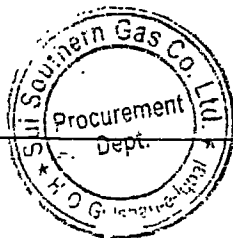

HAZARD CONSEQUENCE RATING TABLE	
Catastrophic	Hazard may cause death or total loss of one or more bodily functions. In case of failure a huge financial loss will occur.
Significant	Hazard may cause severe injury, illness or permanent or partial loss of one or more bodily functions (e.g. prolong exposure to asbestos resulting in Asbestosis or prolong exposure to paint fumes resulting in Chronic Lung Disorder), or serious property damage, loss that may result in disruption of SSGC core activities.
Harmful	Hazard may cause a reportable incident i.e. an incident that results in the employee being unable to undertake their normal duties and may need medical treatment, or property damage, loss that result in partial disruption of SSGC core activities.
Negligible	Hazard may cause minor injury, illness or property damage, first aid treatment is required only, very low financial loss.

PROBABILITY RATING TABLE	
Very Likely	Exposure to hazard likely to occur frequently. Similar incidents reported more than once in SSGC during last 10 years.
Likely	Exposure to hazard likely to occur but not frequently. Similar incidents reported once in last 5 years in SSGC.
Unlikely	Exposure to hazard unlikely to occur.
Highly Unlikely	Exposure to hazard so unlikely that it can be assumed that it will not happen.

RISK PRIORITY TABLE	
Risk Priority	Definitions of Priority
High	Situation is considered critical, stop work immediately or consider cessation of this operation/task. Must be fixed ASAP, Zonal HSE team leader should take immediate actions.
Medium	Is very important, must be fixed within two weeks, Zonal HSE team leader considers short term and/or long term actions.
Low	Is still important but can be dealt with through scheduled maintenance or similar type of action However, if solution is quick and easy then fix it immediately. Review and/or manage by routine procedures.

MR

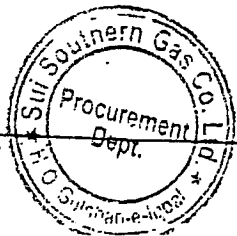

Section 2 Hazard Identification and Risk Assessment

iii. Risk/Impact Assessment Outputs

The output of risk/impact assessment may include the following:

- a. Identified operations of all hazards/aspects and risks/impacts associated with company activities/system etc.
- b. Classification of risk/impact.
- c. Description or reference to control the risks/impacts.
- d. Description or reference to monitor the risks/impacts.
- e. Identified competency and or training requirements.
- f. Input for setting improvement objectives and programs for its achievement.

The risk/impact measures identified shall include controls such as termination/elimination, treatment of the risk/impact and substitution of risk by suitable means and where required tolerated as long as it meets local laws/legislation.

Use output of risk/impact assessments as input for the following:

- a. Setting objectives and targets.
- b. Training needs identification.
- c. Terminating the risk/impact if it is practical.
- d. Facility engineering control.
- e. Emergency Preparedness.
- f. Administrative controls.
- g. Insurance.

The ultimate requirement is to reduce the risk/impact to a level as low as reasonably practical (ALARP) i.e. where the trouble, difficulty and cost for further reduction becomes unreasonably inconsistent to the additional risk reduction obtained.

iv. Risk Control

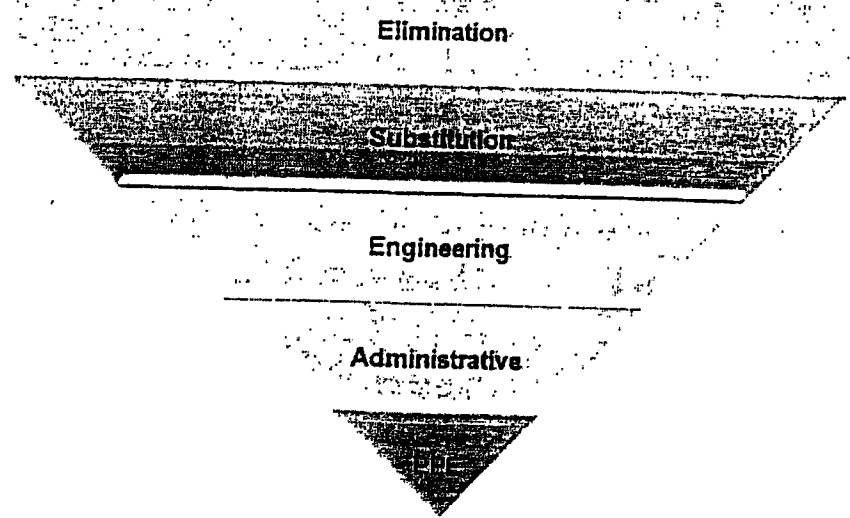

MR

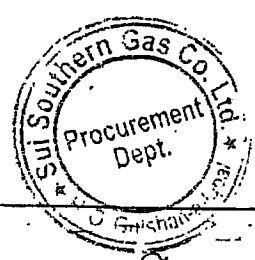

- The hazards and risks are controlled through 'operational controls' by considering the following hierarchy.
- Elimination:** The best way to control a hazard is to eliminate it. This can be achieved by making changes to the work process so that the task is no longer carried out, or by physically removing the hazard altogether. Elimination is the most effective way to control hazards and should be used whenever possible.
 - Substitution:** Substitution is the second most effective method for controlling hazards and risks. It is similar to elimination but involves the substitution of one higher priority risk by another lower priority risk.
 - Engineering:** Engineering controls are implemented by making changes to the design of an equipment or process to minimize its hazard. Engineering controls are based on the concept of "Doing it right the first time". Departments shall incorporate this concept during planning phase of any project/process and must seek out for best possible solution in terms of OHS&E.
 - Administrative:** Administrative controls involve making changes to the way in which people work and promoting safe work practices via education and training. Administrative controls may involve training employees in operating procedures, good housekeeping practices, emergency response in the event of incidents such as fire or employee injury, and personal hygiene practices.
 - Personal Protective Equipment (PPE):** Use of PPE will kick-off where no other controls stated above are possible. PPE should be properly identified for specific process/job.

System & work area Hazards	Likely Consequences
Access / Egress Obstructions	Minor injury, trips and falls
Asphyxiate Gas (CO ₂ fire suppression)	Possible death by asphyxiation
Buried Cables	Exposure to buried cables – major / minor injury
Electricity (HV/LV)	Fatality by electric shock or serious burn injuries
Falling Loads / Objects	Serious head and / or body injury
Flammable Vapors / Gases / liquids	Explosion or fire
Flammable Materials	Potential for fire
Hot / Humid Work Environment	Heat stress, disorientation, loss of consciousness
Moving Parts	Entrapment, major or minor injury
Noise	Long term hearing loss, tinnitus
Openings in Floor / Walkways	Falls from height, major injury possible fatality
Flammable Materials / Gases	Creation of hazardous area, fire, explosion.
Heat, sparks and naked flames	Burns to exposed skin
High intensity light (welding)	Arc flash, short term discomfort, long term loss of vision
Housekeeping poor	Slip, trip, fall, fire hazards, blocking fire escapes
Lifting Operations	Falling or moving loads - serious head and / or body injury
Live Electrical Work	Fatality by electric shock or serious burn injuries
Lone Working	No emergency response if injured.
Long Working Hours	Major / minor accident due to fatigue
Manual Handling	Muscular / skeletal injuries
New Task / Operation	Major / minor injury resulting from mistakes

MR

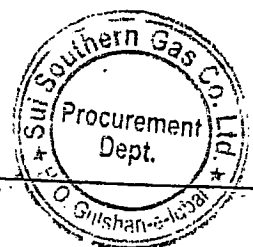

Oxygen deficiency	Death of asphyxiation
Poor Lighting / Visibility	Minor / major injury, fall or impact injury
Slipping / Tripping Hazards	Minor injury, trips and falls
Spillages (Oil and chemicals)	Land contamination
Substances hazardous to health	Chemical burns, toxic, poisoning, irritants, pollutant
Repetitive Task / Operation	Muscular / skeletal injuries
Rotating / Moving Part	Major injury, potential for fatality
Sharp Edges / Cutting Surface	Amputation and cuts, predominantly to hands
Smoke / Fume	Unconsciousness, respiratory problems
Trailing Cables and Hoses	Tripping hazard causing major / minor accident
Use of Hand Tools	Minor laceration and impact injuries
Use of Hazardous Substances	Burns to skin, eyes, and respiratory system. Environment Hazards
Use of Power Tools	Impact injury, hand / arm vibration - loss of sensation over time
Use of Workshop Equipment	Major / minor injuries - entrapment, cutting tools
Vibration	Hand / arm vibration - loss of sensation over time
Work at Height	Major / minor injury

v. Environmental Aspect Identification & Impact Assessment

a. Environmental Aspects:

An Environmental aspect is any element of SSGC business operation that negatively affect the Environment. While conducting environmental assessment, following aspects are usually considered:

"REDUCE CARBON FOOTPRINT"
What we can do:

- Recycle: what you can
- Reduce: avoid unnecessary consumption of resources
- Reuse: Buy items that are reusable and reuse them
- Unplug electrical devices that are not in use
- Avoid unnecessary driving
- Use LED bulbs.
- Plant a tree

Emissions to air	Water Discharges
Solid non-hazardous waste	Solid Hazardous Waste
Consumption of natural resources/ Energy	Noise
Heat	Odor
Dust	Vibration
Effect on visual / aesthetics	Use of Ozone depleting substances
Use of radioactive / nuclear material	Spillage of chemicals

For identification of environmental aspects and impact, each process/activity/equipment is assessed for its inputs and outputs. The inputs can be raw materials, utilities, energy etc. The output can be atmospheric emissions, liquid effluents, noise, hazardous/non-hazardous wastes, vibration etc.

The inputs, outputs, environmental aspects, their associated impact and controls are recorded on Environmental Aspect & Impact Assessment Form (SSGC-IMS/CRM-F-02).

MR

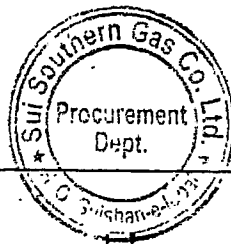

b. Control of Aspects having Significant Environmental Impact:

The significant environmental risks require control measures to eliminate or reduce the impact to a tolerable level either by establishing objective or through application of controls by considering the 4R methodology i.e. Reduce, Reuse, Recover and Recycle.

Some of the suggested operational controls are listed below:

- a. Design of environmental friendly processes/operations.
- b. Isolation or enclosure of hazardous material storage, process or noisy equipment.
- c. Mechanical exhaust systems/booths for controlling toxic materials.
- d. Replacement of potentially unsafe equipment or machinery with new equipment/machines that meet environmental standards.
- e. Electrical or mechanical safety interlock, guards, indicators.
- f. Safety devices (Relieve valves, NRVs, indicators etc.), measuring or monitoring devices/gauges, computerized feedback monitoring and control systems.
- g. Environmental friendly disposal or treatment systems etc.
- h. Fire prevention/suppression systems.
- i. Containment walls.
- j. Scrubbers.
- k. Dust Collectors.
- l. Other controls: Training, SOP.

The record of operational controls on significant environmental risks is maintained on 'Environmental Aspect & Impact Assessment Form (SSGC-IMS/CRM-F-02).

After identification of aspects and assessment of impacts, it is sent to HSE&QA Department for reviewing adequacy and correctness. Where required, In-charge HSE&QA suggests necessary changes or improvement in risk assessment to concerned Zonal HSE Team Leader.

c. Aspect & Impact Assessment Review & Monitoring:

Zonal HSE Team Leader ensures that environmental aspects and impacts related to the activities/processes/equipment are kept current by conducting the same assessment:

- a. Once every six months to update the information, and identify new environmental aspects. (Use SSGC-IMS/CRM-F-02 for recording new hazards and aspects)
- b. Carry out assessment for new or changes in activities/processes/equipment.
- c. When there is a change in laws & regulations.

d. IEE (Initial Environment Examination) / EIA (Environment Impact Assessment):

In addition to all of above assessments, SSGC will carry out IEE / EIA as required by regulatory requirements for new projects. It is the responsibility of corporate HSE&QA head/DMD/MD to ensure the compliance for all new projects.



When combusted;

- One liter of Diesel produces 2.68 kg of CO₂
- One liter of Petrol produces 2.31 kg of CO₂
- One MMBTU of Natural Gas produces 53.07 kg of CO₂

MR

Section 3 Permit to Work

I. Permit to Work (PTW)

A Permit to Work (SSGC-IMS/CRM-F-03) is needed for any routine/non routine activity (Conducted within permanent locations of SSGC) where the work could expose persons to specific hazards. PTW should be acquired and maintained in the zones where job/activity is carried out. Normally following activities require PTW:

- a. Task based Hot Work operation such as welding, brazing, cutting, grinding.
- b. Confined space working. (tank cleaning etc.)
- c. Maintenance Work on High Voltage electrical equipment.
- d. Any janitorial service involving Safety Risks such as work at height.
- e. Any Maintenance activity by any department/contractor which compromises critical safety system.
- f. Work involving interaction with asbestos.
- g. Work in areas where there is a risk of exposure to hazardous chemicals or microorganisms.
- h. Any job/task/activity that requires additional precautions.
- i. Any specific activity performed during development, modification and up gradation of SSGC's Vital Installations including SMS/Valve Assembly/TBS/PRS etc.

II. Exclusion

Following activities are not under the scope of PTW management, however the risk assessment, JSA and or process SOPs are implemented to control the associated risks for the following:

- a. Providing Gas connections to new customers
- b. Emergency Response to Consumer calls (1199)
- c. Planned enhancement of Distribution network
- d. Work on live pipelines like hot tapping, installing Service Tee etc.
- e. Any major/minor rehabilitation/reinforcement work

If it's UNSAFE!

- ✓ Report it
- ✓ Remove it
- ✓ Replace it



MR

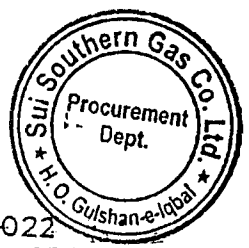
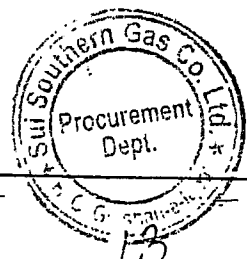

III. Responsibilities

S No.	Functions	Details	Responsibility
1	Executing Authority	The department intends to carry out the task / activity that requires PTW. Situation may arise where Executing Authority is same as Area Authority (e.g. HQs).	Fill out the PTW form. Ensures that task/activity is carried out according to the SOP and controls are implemented to ensure safe operations. Immediately report any incident happened during execution of job to In-charge HSE&QA.
2	Area Authority	Area/Facility where the task/activity is carried out.	Authorize PTW and verify the compliance during the execution of task/activity. Authorized to stop work in case of noncompliance to PTW requirements.
3	Contractor	The Individual/organization carrying out the Task/Activity on behalf of the executing department.	Liaise with executing department to ensure the controls are implemented as per requirement identified in PTW.
4	HSE&QA	HSE&QA will identify the risk/hazards associated with the activity/task and propose controls. In Zones where HSE&QA representatives are not present, Zonal HSE team leader will officiate for HSE&QA responsibilities.	If required, Monitor the task/activity during execution and identify any gaps related to proposed controls. Responsible to close the PTW and maintains records. Authorized to stop work in case of noncompliance to PTW requirements.

MR

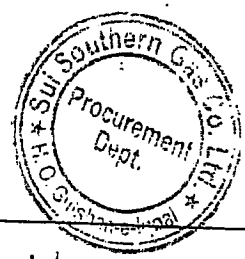

IV. PTW Process Flow

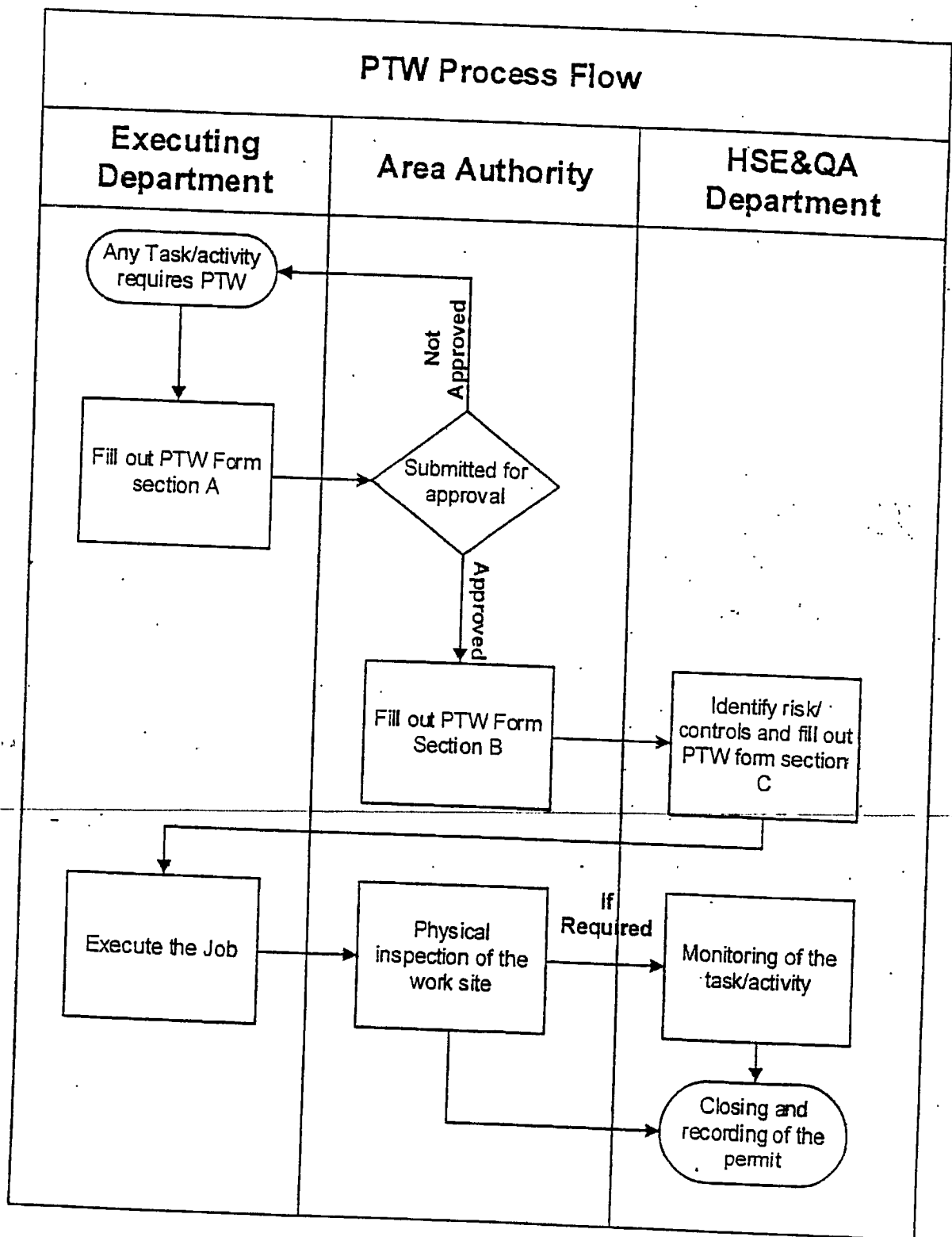

MR

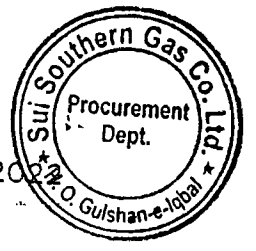
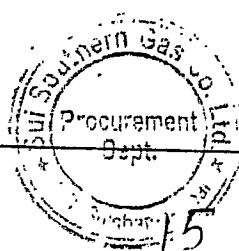

V. Permit Display

Copy of the permit to work should be clearly displayed at the work site or in a location close to where the work activity is being undertaken. Executing department/contractors are also required to ensure that a copy of the permit to work is kept and made available upon request by Area Authority/ HSE&QA.

VI. PTW Closure

Once the task/activity is completed the PTW form is returned back to HSE&QA/Zonal HSE team leader for closing and updating the records. A new PTW is required if the task/activity is not completed within stipulated time frame mentioned on PTW.

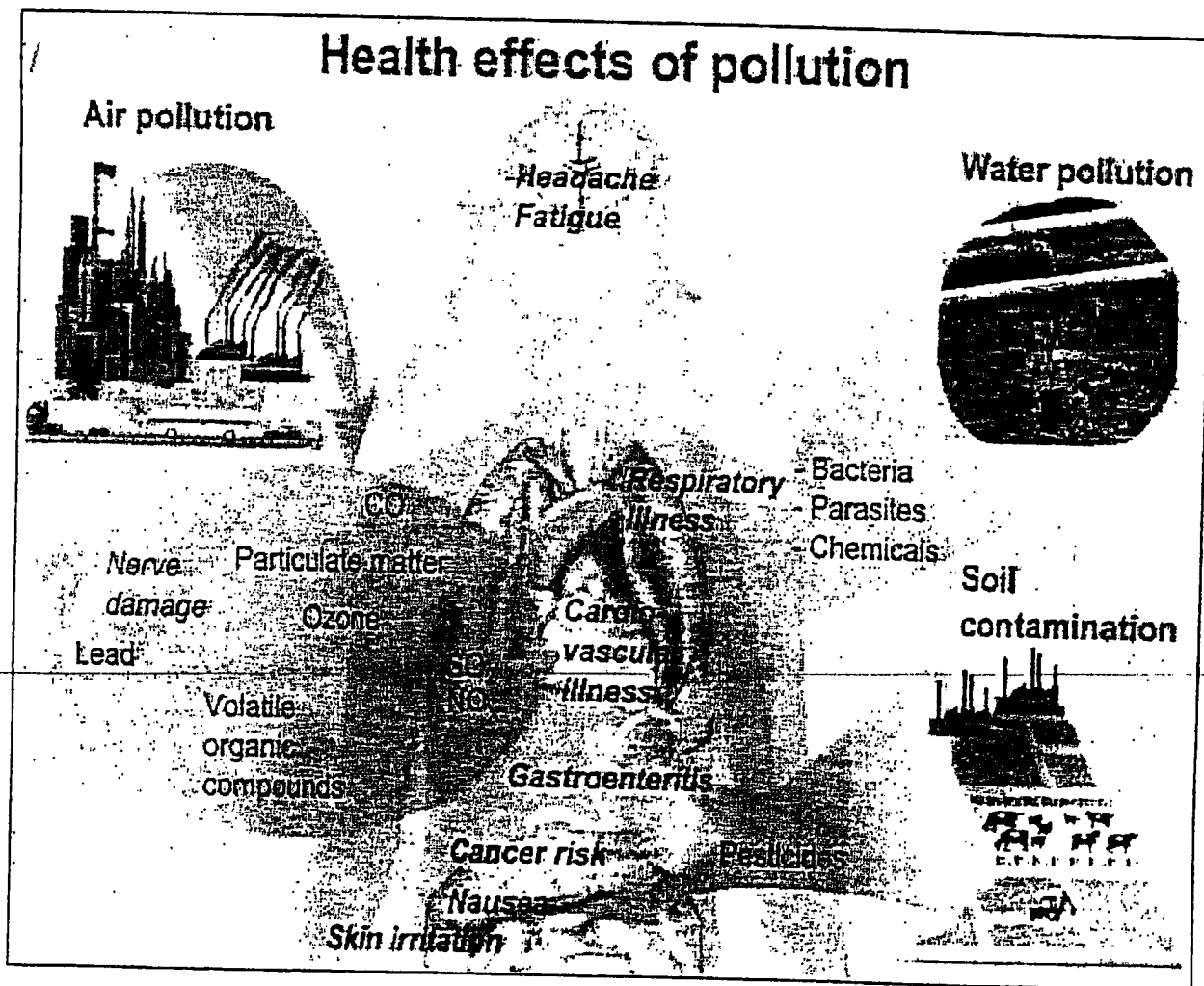

MR

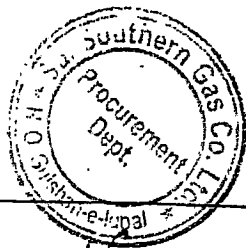

Section 4 Job Safety Analysis

I. Job Safety Analysis (JSA)

Job safety analysis is needed for any routine/non-routine activity (Conducted outside permanent locations of SSGC i.e. Field Locations) where the work could expose persons to specific hazards. Normally following activities require JSA (SSGC-IMS/CRM-F-04):

- a. Work on live pipelines like hot tapping.
- b. Any major/minor rehabilitation/reinforcement/maintenance work on existing distribution/transmission network.
- c. Installing service connection for new schemes. (Blanket JSA may be carried out for each scheme).
- d. Any Emergency maintenance work.
- e. Any particular job/activity requiring JSA as necessitated by HSE&QA.

II. Responsibilities

S No.	Functions	Details	Responsibilities
1	Activity In-charge/ Supervisor	Individual who is assigned to carry out the task/activity requiring JSA.	<ul style="list-style-type: none"> • List down the activities step wise and identify hazards and their controls • Ensure that task/activity is carried with proposed controls • Ensure the team/equipment involved are competent and safe • Report any untoward situation
2	Head Of Executing Department	Head of the department who is authorizing the task/activity requiring JSA.	<ul style="list-style-type: none"> • Authorize JSA • Ensure Adequate resources are provided to carry out the task/activity in safe manner • Select competent team and team leader for the activity/task • Submit a copy of JSA prior to job execution to HSE&QA/Zonal HSE Team Leader.
3	Contractor	The Individual / organization carrying out the Task/Activity on behalf of the executing department.	Liaise with executing department to ensure the controls are implemented as per requirement identified in JSA

MR

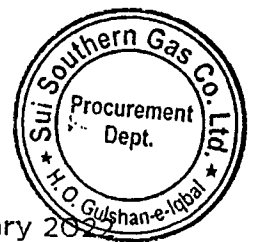
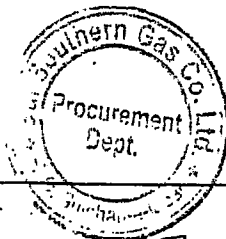

Section 5 Management of Change

I. Management of Change (MOC)

The purpose of this document is to provide all SSGC employees with instructions on Management of Change (MOC) process. Any changes that may affect quality, operations, safety, or the environment will be adequately assessed and must be approved by management or a designated representative of management prior to implementation.

Risk Assessment for any new project, major modification in existing design /facility/ installation will be carried out using MOC methodology.

II. Scope

This procedure is intended to address those changes which may have a direct impact on SSGC's Integrated Management System, or the subsequent delivery of services.

To make sure that changes are assessed and documented in a consistent manner so that

- a. Unnecessary or counterproductive changes are prevented.
- b. Changes do not adversely affect safety, the environment, quality, operations, or the level of service to the client.
- c. No changes are made by individuals without knowledge and/or agreement of all relevant parties.
- d. A record of the assessment rationale and change assessment process is produced.
- e. To make sure proper change out of employees during operations is addressed.

III. Responsibility

- a. **MOC Owner:** MOC owner is responsible to fill out the designated section of the MOC form (SSGC-IMS/CRM-F-05) which briefly describe the details/scope of the project.
- b. **Area Authority:** Area authority is responsible to identify the possible impacts of the change that is taking place. Generally geographical head/zonal HSE team leader is considered the area authority.
- c. **HSE&QA Department:** HSE&QA Department is responsible to authorize the change after assessing the risk and their controls.

MR

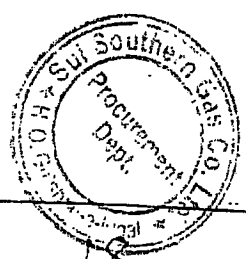

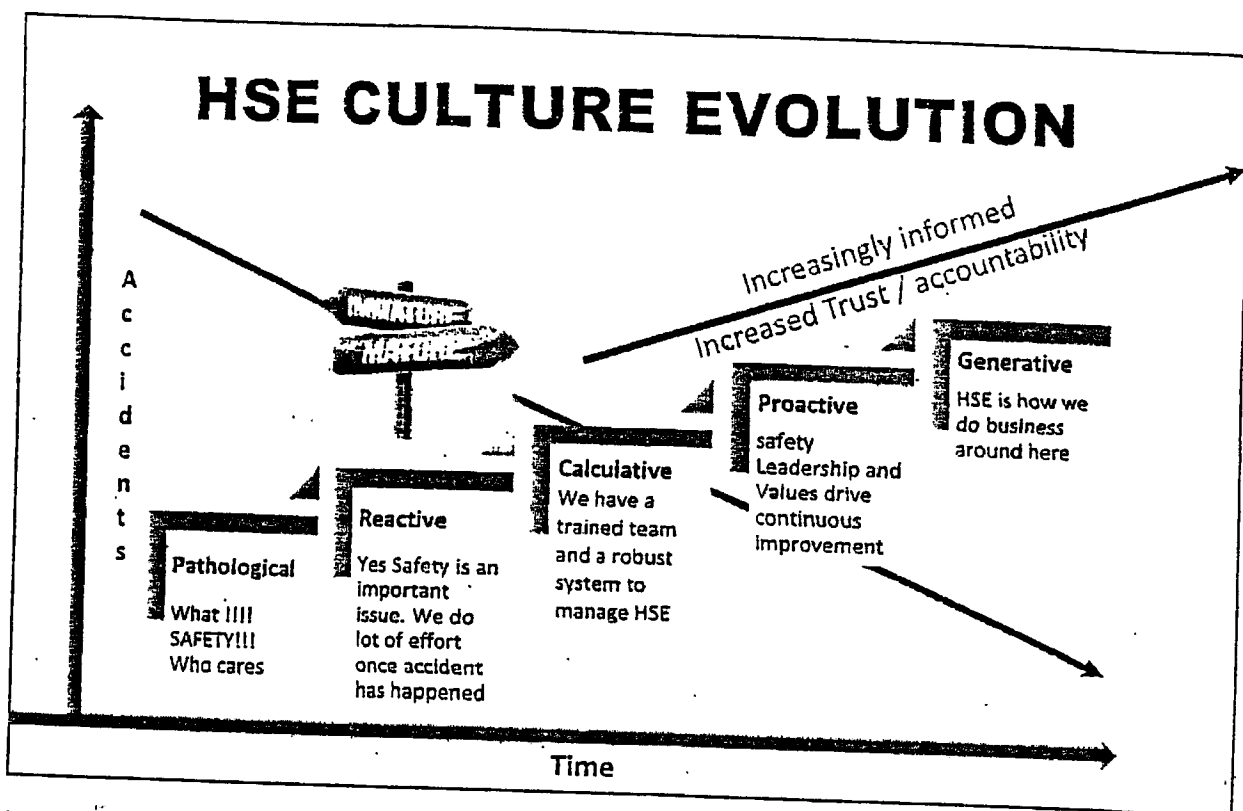

IV. Definition of Change

For the purpose of this procedure a "change" is an alteration to Processes;

- a. Documented information maintained by this IMS.
- b. Equipment, hardware, software, infrastructure.
- c. Personnel assignments and training.
- d. Vendor selection and management.

Other types of changes not listed above can be related to any element of the process, such as inputs, resources, persons, activities, controls, measurements, outputs, etc.

Note: Not all alterations to a system require the Management of Change Process (MOC) (e.g. changing employees, editorial changes to HSE & QA procedures and forms, etc.)

V. Levels of Change

Level 1

- a. Change which has limited or no effect on deliverables, operations, safety, work environment, etc.

Level 2

- b. Changes to equipment, procedures and employee assignments that have a moderate impact on deliverables, operations, safety, or work environment.

Level 3

- c. Changes to equipment, procedures and employee assignments that have a major impact on deliverables, operations, safety or work environment.

MR

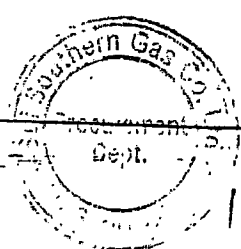

19

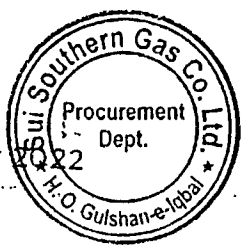

VI. Change Procedure

Step 1 – Initiation of Change

Any employee or contractor that becomes aware of a need for change can initiate the MOC process. The originator will notify their immediate Supervisor/Manager, detailing the proposed change on the MOC form (SSGC-IMS/CRM-F-05). With concurrence by their Supervisor / Manager, the MOC form shall then be forwarded to In-charge HSE&QA for review.

Step 2 – Review by in-charge HSE&QA

In-charge HSE&QA will review the MOC request for potential operational impact, cost/benefit analysis, and associated risk, with input from the appropriate process owners (Moderate Impact) and/or SSGC top management (Major Impact), as appropriate to the change under consideration. Changes that have negligible impact may be processed by the Management Representative directly.

If the request is accepted, In-charge HSE&QA will detail any actions deemed necessary to control the impact of the change and forward the request to the appropriate process owner for implementation.

Step 3 – Implementation of Actions

The process owner will be responsible for implementing and coordinating the actions required for the proposed change. If it is determined that further assessment is required during the course of implementing the change, these assessments will be documented and submitted for review prior to completing the change process. Only after all assessments have been reviewed shall the MOC process be continued and monitored through completion.

VII. Closing out the MOC

The In-charge HSE&QA will review the satisfactory implementation of the proposed change, and effectiveness of any corresponding control measures.

VIII. Record Keeping

The In-charge HSE&QA will retain a log showing each MOC (Control Number of Log) and file the initial MOC request (SSGC-IMS/CRM-F-05) with all information supporting the actions taken throughout the MOC process. These records shall be maintained for a minimum of 3 years.

MR

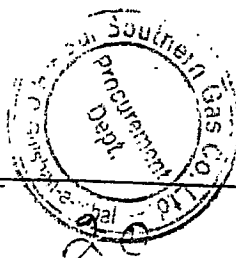

MOC Process Flow

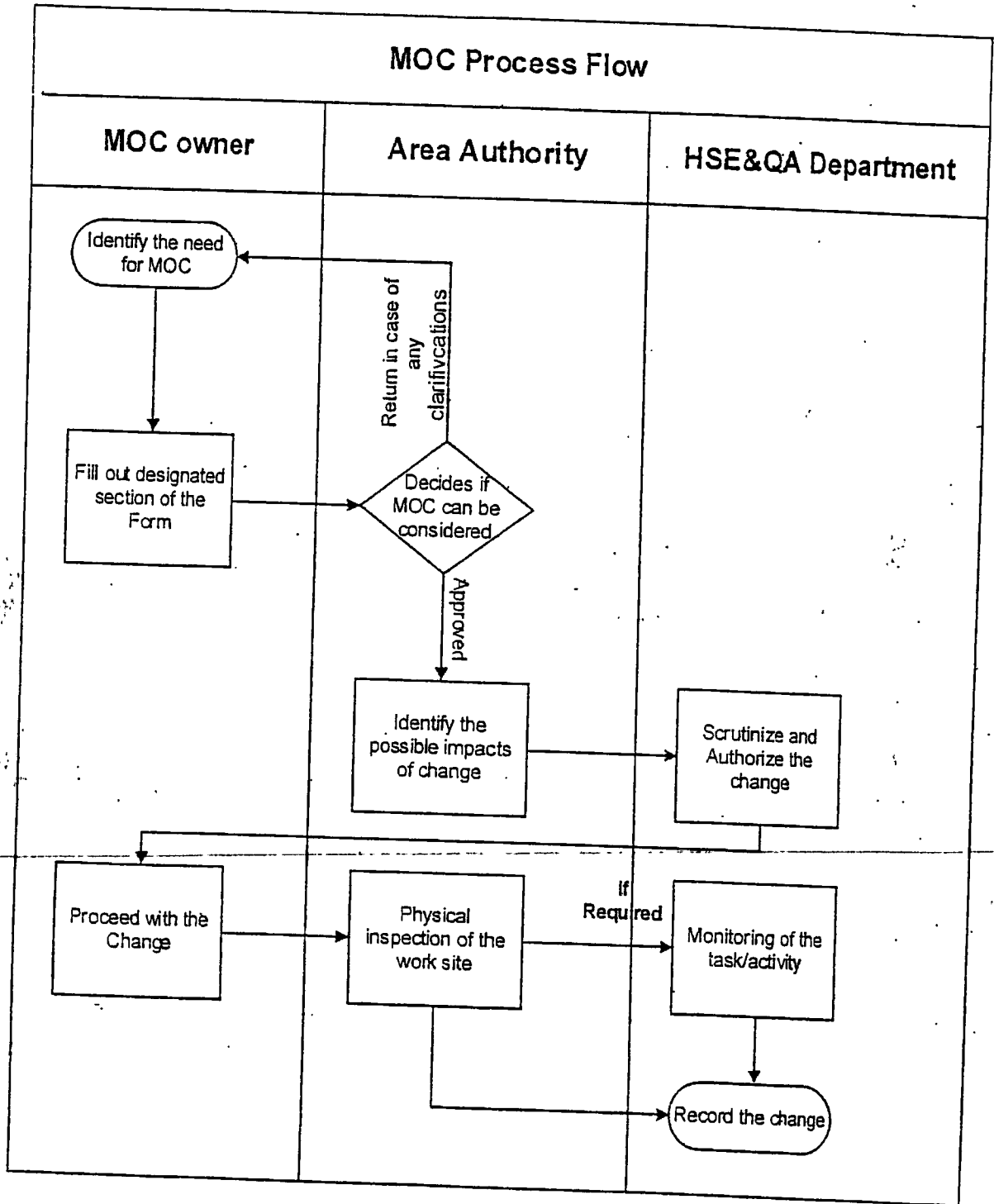

MR

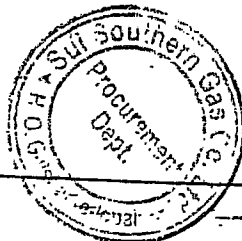

7. TYPICAL SSGC OPERATIONAL HAZARDS AND THEIR POSSIBLE CONTROLS

Some of the common Hazards related to SSGC operations are tabulated below and may be used while doing Risk assessment. There might be other hazards related to a particular activity/ operation or process. These hazards should be identified accordingly along with possible controls.

7.1. PHYSICAL

Hazards	Control Measures
Adverse weather	Shelter, personal protective equipment (PPE; cold / wind / rain-proof).
Poor / Bad housekeeping	Improved safety attitude; good management, safety inspection, good work layout.
Contact with hot / cold surfaces	Insulation, guarding, PPE (gloves, face shields, insulated clothing).
Drowning	Life guarding, lifesaving equipment, presence of first Aider.
Excavation work	Physical barriers; fencing, shoring, safe system of work, signs, caution tape.
Fall from height	Edge protection; safety lines / harnesses, safe means of access, (e.g. scaffolding), safe system of work (e.g. permit to work).
Fall of material from height	Alternative storage, physical means of securing.
Lighting	Good work area design and lighting equipment, measuring of illumination (LUX level), appropriate lighting.
Awkward lifting while laying pipes in trenches	Define weight limits, use mechanical means for lifting and laying of pipes.
Noise	Reduction at source, insulation, PPE.
Slips / Trips / Falls on same level	Good maintenance of work areas, good housekeeping, good cleaning, good footwear.
Stacking	Good work area layout, height limits, weight limits, strong packing, mechanical assistance.
Vibration	Elimination or reduction at source, damping, insulation, PPE.

MR

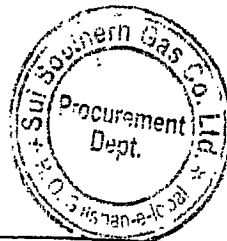

7.2. MECHANICAL

Hazards	Control Measures
Hand tools	Periodic inspection, electrical testing and maintenance.
Machines	Periodic inspection, testing and maintenance, physical barriers (guarding), safety interlocks, supervision and training.
Mechanical lifting operations	Periodic inspections, maintenance, supervision and training.
Manual handling	Regular assessment of handling techniques, improvisation to eliminate stress / fatigue, training in good lifting techniques.
Moving vehicles	Good road layout within premises, proper signs, vehicle maintenance, speed limit, enforce SSGC driving policy, defensive driving classes.
Over Pressure	Proper identification of pressure vessels, preventive maintenance, pressure indicators, alarms, PRV's where required, periodic inspection.

7.3. ELECTRICAL

Hazards	Control Measures
Live working	Avoid (i.e. No Live Working), use competent / trained staff.
Hand tools	Regular inspection, testing of electrical integrity and replacement (where appropriate).
Heaters (elements)	Isolate from combustible material, guarding.
Machines / Electrical cables	Electrical testing and maintenance, good electrical safety design, periodic inspection for design load vs actual load, use of circuit breakers, lockout/ tag out, anti-static materials, Use double insulation, proper grounding.
Electrical cables / cords	Use factory assembled cords, always use plugs, no naked wires.
Power Lines (Overhead / Buried)	Look out for signs, contact local utilities (KE, WAPDA) for locations, stay at least 10 feet away from overhead lines, use proper PPE.

MR

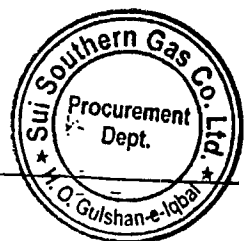
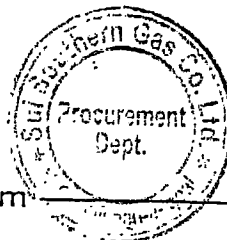

7.4. FIRE

Hazards	Control Measures
Combustible materials	Avoid, reduce storage of combustible materials, isolate from sources of heat and ignition.
Flammable gases	Storage of gas cylinders (e.g. hydrogen, acetylene) outside in an isolated, well-ventilated area; signs, no smoking, color-coding.
Flammable solvents	Controlled storage, use and disposal (e.g. limit quantities held), fire proof storage, signs, no smoking, no naked flames, emergency plans.
Heaters	Segregation from sources of combustion, guarding special construction if used in hazardous areas.
Oxidizing agents	Chemicals that are a source of oxygen, e.g. hydrogen peroxide, segregate from sources of combustion (e.g. flammable solvents).
Oxygen (gas and liquid)	Segregate from sources of combustion, controlled storage and usage.
Smoking materials	Designated smoking areas with proper ventilation; promote no smoking policy.
Static electricity	Limit use of static generators in hazardous areas. Use of anti-static devices; earthing.
Gas Leaks	Odourization for timely detection where possible, proper joining methods, Field survey, training, leak detection techniques.

7.5. OTHER

Hazards	Control Measures
Chemical: Chemical substances, Corrosives (acids, alkalis), Carcinogens, Irritants (e.g. Ammonia)	Avoid use, substitute less harmful substances, use, maintain and test engineering controls, monitor for hazardous substances; inform and train employees, use personal protective equipment (PPE), emergency plans for uncontrolled releases.
Biological: Biological agents: (micro-organisms; pathogens, mutagens, carcinogens), Rodents, Snake Bite	Avoid use, substitute less harmful substances, use maintain and test engineering controls, monitor for hazardous substances, inform and train employees, use personal protective equipment (PPE), emergency plans for uncontrolled releases. Periodic rodent control drive, identification and elimination of snakes and other harmful reptiles specially in remote locations of SSGC.
Food / Water safety	Good food hygiene standards, good cleaning / disinfection, employee information and training, good personal hygiene, protective clothing. Testing if required from accredited lab (AKUH, PCSIR), Involve canteen contractors, credibility of product/Services.
Ergonomics	Educate / Train employees, avoid repetitive tasks, procure ergonomically design products (e.g. chair, Computer desk, Tools)

MR

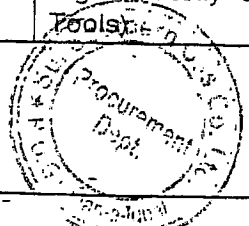

8. DOCUMENTED INFORMATION

Record No.	Record Name	Maintained by	Retention Period
SSGC-IMS/CRM-F-01.	Hazard Identification & Risk Assessment Form	HSE&QA Department	3 Years
SSGC-IMS/CRM-F-02	Environmental Aspect & Impact Assessment Form	HSE&QA Department	3 Years
SSGC-IMS/CRM-F-03	Permit to Work Form	HSE&QA Department	3 Years
SSGC-IMS/CRM-F-04	Job Safety Analysis Form	HSE&QA Department	3 Years
SSGC-IMS/CRM-F-05	Management of Change Form	HSE&QA Department	3 Years
SSGC-IMS/CRM-F-06	Context of the Organization	HSE&QA Department	3 Years
SSGC-IMS/CRM-F-07	SWOT Analysis	HSE&QA Department	3 Years

MR

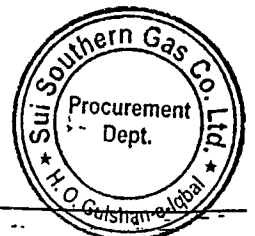
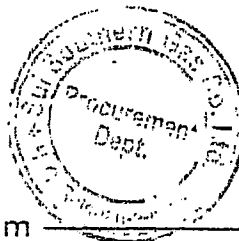

 SSGC HSE&QA Department	IMS Form	SSGC-IMS/CRM-F-01
	Hazard Identification & Risk Assessment Form	
	Revision 01	
Issue Date: July, 2021		

Zone	Department	Location	Date				
S. No	Hazard <i>(E.g. Worn out electrical cord)</i>	What can go wrong <i>(E.g. Electrical shock to any employee)</i>	Existing Operational Control <i>(E.g. Covered with plastic tape)</i>	Risk Priority			Additional Operational Controls <i>(E.g. Isolate/Replace the wire)</i>
				PROBABILITY <i>(E.g. Likely)</i>	CONSEQUENCE <i>(E.g. Significant)</i>	PRIORITY <i>(E.g. High)</i>	
Additional Comments (If any):							
Zonal HSE Team Leader				HIRA Team			
Name & Designation		Signature		S. No	Name & Designation		Signature
				1			
				2			
				3			

MR



 SSGC HSE&QA Department	IMS Form	SSGC-IMS/CRM-F-02
	Environmental Aspect & Impact Assessment Form	Revision 01
		Issue Date: July, 2021

Zone	Department			Location	Date		
Process / Operation Description: (E.g. Power Generation)							
S.No	Activity (E.g. Fuel Combustion)	Input (E.g. fuel, air)	Output (E.g. Hydrocarbons, CO ₂ , H ₂ O, CO, particulate matters)	Environmental aspect (E.g. air emissions)	Environmental impact (E.g. Degradation of air, consumption of natural resources, Depletion of ozone layer etc.)	Risk Priority (High/Medium/Low)	Operational controls
Additional Comments (If any):							
Zonal Team Leader				EAIA Team			
Name & Designation	Signature	S. No	Name & Designation	Signature			
		1					
		2					
		3					

MIR

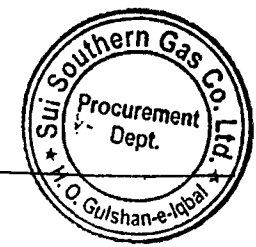
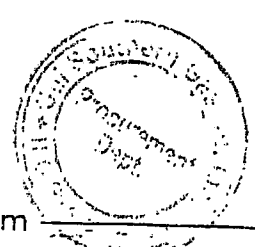



E-02

 SSGC HSE&QA Department	IMS Form	SSGC-IMS/CRM-F-03
	Permit To Work Form	
	Revision 01	
Issue Date: July, 2021		

Work Permit Number (To be filled by HSE&QA):					
Section "A"					
To be filled by Executing Department	Department Name:		Contractor Details (If Any):		
	Responsible Person	Name:	Contact Name:		
		Signature:	Signature:		
	Permit Valid From	Time:	Permit Valid Until	Date & Time:	
		Date:		Time:	
Date:		Date:			
Location of the Work:					
Type of Work(s)			Detail of Work		
<input type="checkbox"/> Hot Work <input type="checkbox"/> Electrical maintenance work <input type="checkbox"/> Mechanical maintenance work <input type="checkbox"/> Hazardous chemicals <input type="checkbox"/> Working at height <input type="checkbox"/> Working in confined spaces <input type="checkbox"/> Working with compressed gases <input type="checkbox"/> Janitorial/Cleaning Service <input type="checkbox"/> Excavation/Trenching <input type="checkbox"/> Handling Asbestos <input type="checkbox"/> Lifting or hoisting <input type="checkbox"/> Other (Please provide details)					
Equipment/tools to be used:					
Please mention the associated hazards of this activity (Please refer IMS Procedure: Context, Opportunities & Risk Management):					
Following services to be isolated / locked off (if required)					
<input type="checkbox"/> Electricity <input type="checkbox"/> Gas <input type="checkbox"/> Water <input type="checkbox"/> Air <input type="checkbox"/> Other					
Section "B"					
To be filled by Area	I authorize the task / activity to be carried out at above mentioned location for specified time. Executing Department should carry out work in compliance to safety / PPE requirements identified by HSE&QA Department in section 'C'				
	Name	Designation	Signature		
	Date and Time				
Section "C"					
To be filled by HSE&QA	Name	Designation	Signature		
	Date				
	Following controls must be implemented to mitigate the safety risk/hazard associated with the task/activity:				
PPE Required:					
<input type="checkbox"/> Hard Hat <input type="checkbox"/> Safety Shoes <input type="checkbox"/> Cover all <input type="checkbox"/> Reflective Jackets <input type="checkbox"/> Ear Plug <input type="checkbox"/> Ear Muffs <input type="checkbox"/> Dust Mask <input type="checkbox"/> Face Shields <input type="checkbox"/> Welding Shields <input type="checkbox"/> Safety Belt/ Harness <input type="checkbox"/> Safety Goggles <input type="checkbox"/> Hand Gloves <input type="checkbox"/> Breathing Apparatus					
Others:					
Any additional operational controls (Please Specify):					
<input type="checkbox"/> Fire Extinguisher <input type="checkbox"/> Ambulance <input type="checkbox"/> Barricade <input type="checkbox"/> Other:					
Section "D" (Monitoring & Closing)					
Area Authority		Executing Department		HSE&QA Department	
I have physically inspected the work site and verified the operational controls are in place.		I declare that the above task / activity has been carried out in compliance with the controls / requirements mentioned above.		HSE&QA Observations during monitoring (if any):	
		The task / activity is now completed and site is safe for routine operations.			
		Any incident happened during execution:		This work permit is now considered close.	
Yes <input type="checkbox"/> No <input type="checkbox"/>					
Name	Sign & Stamp	Date	Name	Sign & stamp	Date

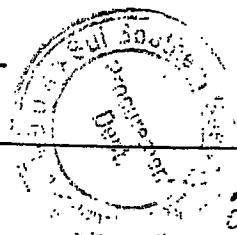
MR



 SSGC HSE&QA Department	IMS FORM	SSGC-IMS/CRM-F-04
	Job Safety Analysis Form	
	Revision 01	
Issue Date: July, 2021		

Executing Department	Zone	Date
Job/Activity:	Activity Details:	
Location:		

PPE Required:
 Hard Hat Safety Shoes Cover all Reflective Jackets Ear Plug Ear Muffs Dust Mask
 Face Shields Welding Shields Safety Belt/ Harness Safety Goggles Hand Gloves
 Breathing Apparatus Others:
Any additional operational controls (If required)
 Fire Extinguisher Ambulance Barricade Other:

S.No	Steps of field Activity	Potential Hazards	Controls

Activity Incharge / Supervisor			Head of Executing Department		
I hereby certify that all operational controls, mentioned above, will be implemented at each step of the job. The team is trained to execute the job and the equipment involved in this activity are safe to operate.			I authorize the team to conduct the job. The team is adequately resourced to execute the job safely.		
Name & Designation	Sign & Stamp	Date	Name & Designation	Sign & Stamp	Date

MR

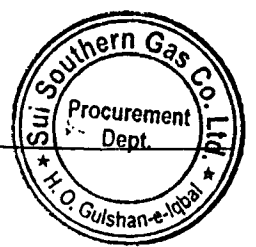



CRM-F-04

 SSGC HSE&QA Department	IMS FORM	SSGC-IMS/CRM-F-05
	Management of Change	Revision 01
		Issue Date: July, 2021

	MOC No: _____	Date _____
To be filled by MOC Owner	Section A : Description of proposed change and potential hazards	
	MOC Owner _____	Location of Work: _____
	Expected Duration of Work _____	
	Type of Change	
	<input type="checkbox"/> Permanent <input type="checkbox"/> Temporary	<input type="checkbox"/> Pipeline construction <input type="checkbox"/> Physical structure/building <input type="checkbox"/> New or modification in process/procedure <input type="checkbox"/> New or modification in equipment/machine <input type="checkbox"/> Material <input type="checkbox"/> Substance <input type="checkbox"/> Other: _____
	Detail of MOC/Scope of MOC: (Summarize the basis for the proposed change and any potential health, safety and environment impacts resulting from the proposed change.)	
	The proposed change is now submitted to Area Authority for evaluation.	
	Name & Designation _____	Sign & Stamp _____
		Date _____
	To be filled by Area Authority	Section B : Evaluation of the impact(s) related to the change
Evaluation Criteria		
Does the proposed change meet all applicable legal or other requirements?		Yes No Comments
All modifications in the existing process/ equipment are Environmentally Manageable and Safe?		
Does the change requires changes in SSGC HSE Procedures		
Does the change will affect the use of Emergency response equipment of the location		
Does the change requires any specialized training for SSGC staff		
<i>Note: in case of "YES" please provide details on a separate sheet</i>		
The proposed change is now submitted to In charge HSE&QA for authorization.		
Name & Designation _____	Sign & Stamp _____	
	Date _____	
To be filled by HSE&QA	Section C : Authorization for change to proceed	
	Following proposed controls should be implemented while execution of the job.	
	Potential hazard/risk	Risk level Proposed control Responsibility Timeline
	Name & Designation _____	Sign & Stamp _____
	Date _____	

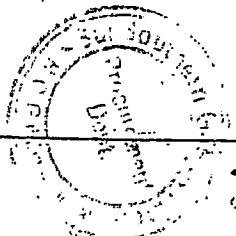
MR



 SSGC HSE&QA Department	IMS Form	SSGC-IMS/CRM-F-06
	Context of the Organization	
		Revision 00
		Issue Date: July, 2021

LIST OF INTERESTED PARTIES

External Interested Parties	Needs & Expectation
Board Of Directors	Profitability, good financial and legal compliance, avoidance of fine and penalty OR <ul style="list-style-type: none"> • Protect shareholders interest. • Ensure adherence / compliance to GOP / SECP guidelines. • Allocate resources to maximize revenue. • Follow best practices of corporate governance. • Ensure committee meetings are held as per plan. • Financial benefits of the organization. • Avoidance of any fines / penalties. • Reputation enhancement.
Management	<ul style="list-style-type: none"> • Corporate Social Responsibility (CSR). • Enhanced corporate governance (CG). • Allocation of all resources to achieve quality goals. • Achievement of safe and healthy conditions in organization. • Commitment to quality, safety and health. • Be prepared to seek advices from industry experts as required. • No major accident at company premises.
Management	<ul style="list-style-type: none"> • Take policy decisions to increase revenue per employee.

MR

31

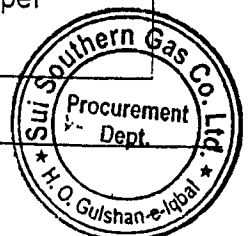

CRM-F-06

 SSGC HSE&QA Department	IMS Form	SSGC-IMS/CRM-F-06
	Context of the Organization	Revision 00
		Issue Date: July, 2021

	<ul style="list-style-type: none"> • Ensure that policy and related objectives are established. • Communicate clear roles to employees. • Develop, lead and promote culture in the organization. • Meet organizational goals by assigning targets to right personnel. • Demonstrate leadership at all levels and functions of the organization. • Effective management of hazards, risks, incident, emergency, and injury. • Workers engage and participation in all quality, environment, health and safety activities. • Continued growth in quality and productivity. • Effective controls on quality, health & safety issues.
	<ul style="list-style-type: none"> • No major accident at workplace / safe working conditions for all employees. • Develop positive quality and health & safety culture. • Continuously improve quality, safety and health performance with review process. • Well performed employees. • Better staff retention and morale.
Staff & Workers	<p>Continuation of job, timely wages with all applicable benefits to pay the cost of living, professional development and growth via regular trainings.</p> <p>OR</p> <ul style="list-style-type: none"> • Good and safe working conditions. • Job security.

MR

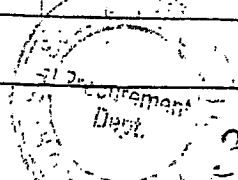

32

 SSGC HSE&QA Department	IMS Form	SSGC-IMS/CRM-F-06
	Context of the Organization	
	Revision 00	
		Issue Date: July, 2021

	<ul style="list-style-type: none"> • Training and development opportunities. • Sustained reputation and image of company. • Consultation. • Communication and participation. • No accident / injury / ill-health. • Reward and recognitions. • Opportunities for dialogue / improvement / changes. • Timely and fair provision of remuneration coupled with career progression.
Client/Customer	Timely provide high quality services, quick response on any complaint, follow all local laws and QH&S requirements. OR <ul style="list-style-type: none"> • Uninterrupted gas supply. • Customer facilitation. • Quick response of queries & complaints.
	<ul style="list-style-type: none"> • Value for money. • No health and safety issue in product. • Prompt actions on quality, health and safety issues. • Minimize the risk of injuries when receiving a services. • Socially and environmentally responsible.
Suppliers/Contractor	<ul style="list-style-type: none"> • Continuous orders, prompt payments as per agreed terms, good long terms working relationship. • Fair chance of participating in bid opening. • Communication of hazards present at workplace. • Timely payment.

MR

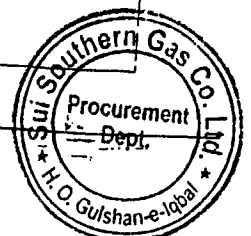

CRM-F-06

 SSGC HSE&QA Department	IMS Form	SSGC-IMS/CRM-F-06
	Context of the Organization	
	Revision 00	
		Issue Date: July, 2021

	<ul style="list-style-type: none"> • Transparency.
Trade Union & Worker Representative	<ul style="list-style-type: none"> • Effective implementation of national & local labor laws with any non-conformance, good working relationship with management • Conducive and safe environment for work • Timely provision of information necessary for workers • No fear of dismissal or disciplinary action while reporting near miss / accident.

External Interested Parties	Needs & Expectation
Media & NGOs	<ul style="list-style-type: none"> • Media management. • Patient and positive attitude. • Effective communication.
Visitors	<ul style="list-style-type: none"> • Safe entry and exit during stay at SSGC. • Communication of pertinent information. • Emergency response. • Briefing necessary safety rules. • Necessary PPE available. • Site access controls.
Emergency Services (Fire/Medical etc)	<ul style="list-style-type: none"> • Good Risk management. • Emergency procedure in place and drilled. • Regulatory compliance.

MR

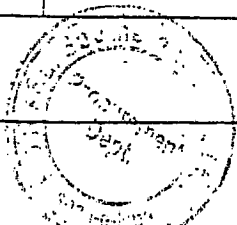

34

 SSGC HSE&QA Department	IMS Form	SSGC-IMS/CRM-F-06
	Context of the Organization	
		Revision 00
		Issue Date: July, 2021

	<ul style="list-style-type: none"> Regular drills for flooding, spillage, site excavation and first aid etc. Availability of adequate resources.
Utility Providers (Power/water/fuel, Telecom)	<ul style="list-style-type: none"> Prompt payment. Good Management.
Academic Institutes	<ul style="list-style-type: none"> Effective learning programs for employees. Synchronize the linkage of quality, health and safety with technical and non-technical learnings. Learning from SSGC.
Insurance Companies	<ul style="list-style-type: none"> No claims, risk management, prompt payment.
Banks	<ul style="list-style-type: none"> Financial performance, cash flow.
Neighborhood/Community/ Society	<ul style="list-style-type: none"> Safe working conditions. Environment friendly operations. Contribute positive to local environment and populations.
	<ul style="list-style-type: none"> No complaint relating to noise, pollution, waste and employment.
Share Holders	<ul style="list-style-type: none"> Minimize risk and losses. Increase market capitalization. Return on investment. Transparency. Rights are protected. Good dividend.
Federal and local law enforcement agencies	<ul style="list-style-type: none"> Pay all applicable taxes timely, follow local laws and regulations with regular updating

MR

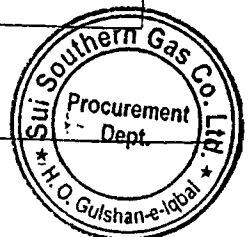

MS-F-06

 SSGC HSE&QA Department	IMS Form	SSGC-IMS/CRM-F-06
	Context of the Organization	Revision 00
		Issue Date: July, 2021

Third party auditors- Finance	<ul style="list-style-type: none"> • Smooth data collection • Better financial performance • Effective communication • On time response on queries • No fraud or illegal acts detection
Certification bodies	<ul style="list-style-type: none"> • Effective implementation of ISO standards with all relevant clauses in the organization
Creditor/Financial Institution	<ul style="list-style-type: none"> • Repaid on time, good financial performance
Government/ Regulators (Local/Regional/Provincial/ National/International)	<ul style="list-style-type: none"> • Identified applicable statutory and regulatory requirements for Quality and health & safety. • Prompt responses in case of any non-conformance. • Proper investigation on uncontrollable. • <u>Implementation of safe policy in the field of occupational safety.</u>
	<ul style="list-style-type: none"> • Fulfill the requirements of all applicable laws, rules, regulation, orders, guidelines, interpretations and directives.

MR



 SSGC HSE&QA Department	IMS Form	SSGC-IMS/CRM-F-07
	SWOT Analysis	
	Revision 00 Issue Date: July, 2021	

POSITIVE	
STRENGTHS	WEAKNESSES
Having vast experience of Transmission and Distribution of Natural gas.	Complex distribution network leading to UFG.
Infrastructure available in two provinces.	Substantial resources required for up gradation.
Highly competent human resource.	Lack of succession planning.
Certified to international standards.	Takes extra time to implement all requirements because of big size of the organization.
Sole Meter manufacturing plant in Pakistan.	High price.
Serving the nation since decades.	Government new rules implementation.
Positive image of the company is already established in the Society.	Resource transfers.
NEGATIVE	
OPPORTUNITIES	THREATS
Monopolistic market.	Depleting natural gas.
Over 2.8 million customers.	Customers may turn to renewable energy sources.
Import of LNG.	High cost.
Huge infrastructure of Transmission and Distribution to connect new customers.	Gas theft and leakages resulting in huge loses.
Reduction in the lead time to facilitate complainant.	Change in Government policies.
Advancement and use of latest technology to control the system will create more effectiveness.	Criminals threats on security.

MR

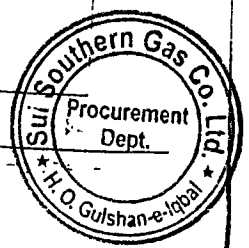

1. PURPOSE

The purpose of this document is to define a mechanism of incident and near miss reporting investigation & propose corrective/preventive actions against near miss, incidents and accidents.

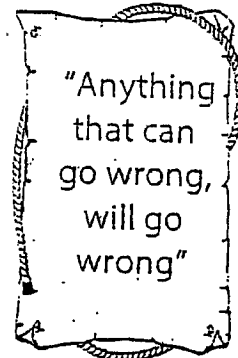

2. SCOPE

This procedure is applicable to all incidents (i.e. accidents & near miss) which take place within SSGC premises or outside SSGC premises i.e. its installations or work -related sites which are under the scope of management system.

3. DEFINITION

- a. **Incident:** Work-related event(s) in which an injury or ill health or property damage (regardless of severity) or fatality occurred, or could have occurred.
- b. **Accident:** An incident in which an injury or illness or property damage actually occurs.
- c. **Near Miss:** A Near Miss is an unplanned event that did not result in an injury or property damage, but had the potential to do so.
- d. **CPR:** Cardiopulmonary resuscitation.
- e. **Emergency:** An emergency is a situation that poses an immediate risk to health, life, property, or environment.

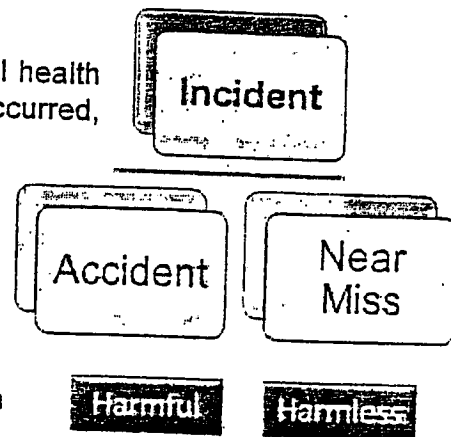

INCIDENT / ACCIDENT LOSSES

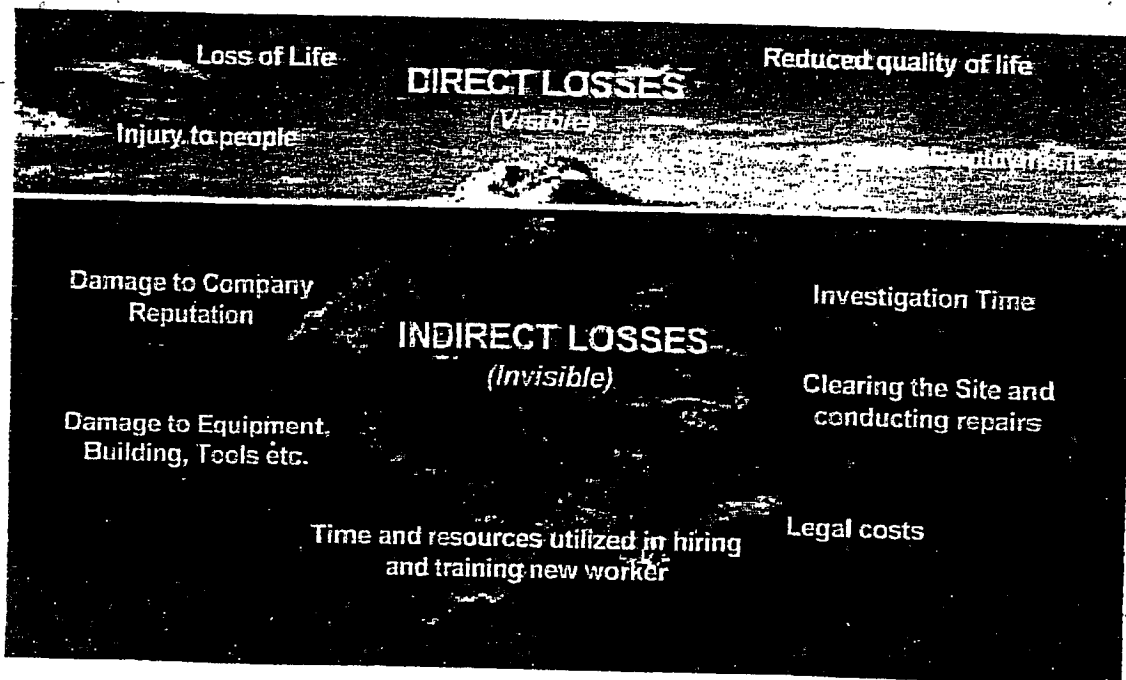

MR

4. PROCEDURE

4.1. Incident Classification Table

S. No	Incident Type	Classification	Actions to be taken	Responsibilities	Record
1	<ul style="list-style-type: none"> Major fire Major gas leakage Explosion Bomb blast Vehicular accident Significant asset / human loss due to any untoward situation including natural disaster, damage or theft of asset / property having an estimated amount of more than Rs. 30,000 Injury/illness serious enough to result in two off workdays. 	Major	Inform respective departmental head/in-charge and immediately call local rescue departments, such as Fire Brigade, Bomb Disposal Squad etc. Thus, whichever is necessary.	Anyone who has witnessed or received initial information about the incident.	
			Follow the Emergency Response Procedure.	Security department in case within SSGC premises, Site/ Zonal HSE team leader in case it is outside the SSGC premises.	SSGC-IMS/ER P-04
			Provide Help/Support to the victims such as First Aid or CPR if needed.	Only trained persons in case of CPR/First Aid is needed.	
			Report the incident using incident notification form via web portal to in-charge HSE&QA immediately (or within 24 hours) after the occurrence of incident.	Zonal HSE Team leader.	SSGC-IMS/IAM -F-01
			HSE&QA will complete the investigation report via web portal within seven working days after receiving incident notification form. Additional days may also be required depending upon the criticality of investigation	HSE&QA	SSGC-IMS/IAM -F-02
			HSE&QA will share the report with all concerned for necessary corrective / preventive actions.	HSE&QA	
			HSE&QA will maintain incident data base using online web portal and will share the information with all concerned to avoid reoccurrence.	HSE&QA	
Implement Corrective / Preventive action.	Zonal HSE Team Leader and anyone who is identified in Investigation report.				
Follow-up to verify the implementation of recommended corrective/preventive actions.	HSE&QA				

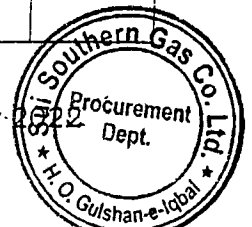

Handwritten marks and numbers: 12/2, 39

S. No	Incident Type	Classification	Actions to be taken	Responsibilities	Record
		Major	In case of gas loss, transmission/distribution department will quantify the amount of gas loss and shares the same with concerned departments along with investigation report.	Transmission/ Distribution	
2	<ul style="list-style-type: none"> Minor Injuries where only basic first Aid or less than two off days provided to the victim. Minor Vehicular accidents where there is no significant injury or loss. 	Minor	Inform respective departmental head / in-charge.	Anyone who has witnessed or received the initial information about the incident.	
			Report the incident using incident notification form via web portal to in-charge HSE&QA within twenty four hours of the occurrence of the incident.	Zonal HSE Team leader.	SSGC-IMS/IAM-F-01
			HSE&QA will share the information with all concerned to avoid reoccurrence.	HSE&QA	
3	<ul style="list-style-type: none"> Any Near Miss Occurred / Observed. 		Report the Near Miss using online Near Miss Notification Form via web portal. Enter details as mentioned on the form attach evidence (if any) and submit.	All Employees	SSGC-IMS/IAM-F-03

4.2. Incident Reporting:

- a. Incident that resulted in personnel injury, spill, fire, asset damage etc. will be considered as accidents and will be reported through online Incident Management System within 24 hours after the accident.
- b. Incident that have not done any damage or lose will be considered as Near Miss and will also be reported via web portal.
- c. All HSE Zonal Team Leaders are responsible to immediately report any incident took place in their respective Zone.
- d. All Employees are responsible to immediately report any Near Miss occurred / observed via web portal.

MR

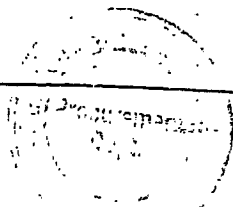

4.3. Investigation and Corrective Action

Incidents are investigated by the team constituted by In-charge HSE&QA. If required, a cross functional team may be formed. Depending upon the situation, Incharge HSE&QA will decide whether to investigate or not any major/minor incident/accident, considering following factors:

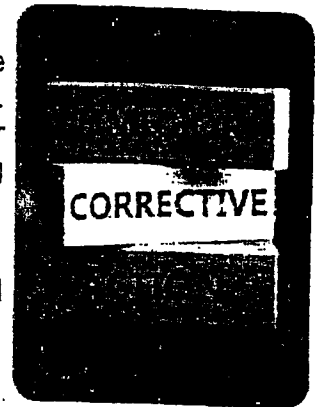

- a. Severity of the incident/accident.
 - b. Time lapse between reporting of the incident and the actual occurrence of the incident.
 - c. Lack of supporting information.
- The investigation is carried out to determine the root cause of the problem. The investigation process covers:
- a. Determination of root cause using any suitable method like tripod analysis etc.
 - b. Investigation will be conducted as soon as possible after the incident, following the activities required controlling the hazard.
 - c. When indicated by the severity of the incident, steps to secure the incident site must be initiated immediately to ensure that investigating party can reconstruct the events leading to the incident.
 - d. Individual interviews will be conducted with each person present at the time of the incident. The following rules are followed for interviews with all individuals:
 1. The witnesses should be interviewed promptly, separately and privately.
 2. The interviewer should avoid questions that give a yes or no answer.
 3. After the interview, the interviewer should document any concerns identified.
 - e. The investigation will be focused at determining the root cause and therefore:
 1. The investigator or investigating team must focus on getting accurate and complete information.
 2. Facts must be separated from opinions, and direct evidence from circumstantial evidence.
 3. Each concern identified in the investigation must be fully addressed.
 - f. Upon completion of the investigation, the team will fill and submit the Online Incident Investigation Form (SSGC-IMS/IAM-F-02). It includes Background Information, Root Cause Analysis, Conclusion and Recommended Corrective / Preventive Actions.
 - g. In all cases, the Incident investigation must be completed within 07 working days from the incident notification date. Depending upon the nature of investigation, in-charge HSE&QA may extend the report submission timeline.
 - h. Determination and implementation of viable corrective/preventive actions to eliminate the causes of incident.
 - i. In-charge HSE&QA / Zonal HSE Team Leader ensures that the corrective/preventive actions assigned to concerned department/personnel, to be completed within agreed time frame.
 - j. It is responsibility of the Zonal HSE Team Leader to:

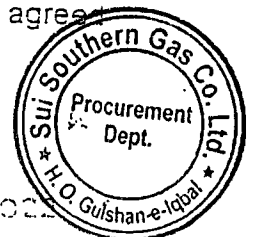

1. Provide leadership role in implementation of corrective/preventive actions within the agreed timescale.
2. Ensure that corrective / preventing actions are effective in eliminating / reducing the risks.
3. Maintain record of Incident Notification Form and Incident Investigation Form of their respective zones.

4.4. Updating of Assessment

After the incident, depending upon the nature of severity and risk, the assessments (risk assessment, environmental aspect impact assessment) of specific activity / department will be updated including controls, risk level, likelihood etc.

4.5. Data Analysis and Review of Actions

The data of incidents will be evaluated and investigation outcomes will be shared with the management during management review meetings to seek advice and to discuss the effectiveness of measures / actions implemented.

5. DOCUMENTED INFORMATION

Record No.	Record Name	Maintained by	Retention Period
SSGC-IMS/IAM-F-01	Incident Notification Form	In-charge HSE&QA / Zonal HSE Team Leader	3 Years
SSGC-IMS/IAM-F-02	Incident Investigation Form	In-charge HSE&QA / Zonal HSE Team Leader	5 Years
SSGC-IMS/IAM-F-03	Near Miss Notification Form	In-charge HSE&QA / Zonal HSE Team Leader	3 Years

MR

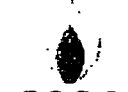
 SSGC HSE&QA Department	IMS FORM	SSGC-IMS/IAM-F-01
	Incident Notification Form	
	Revision 01	
Issue Date: Aug, 2021		

Date: _____ Time: _____ Report No. _____
 (To be filled by HSE&QA)

Reported by: _____

Location: _____

SSGC Premises Outside SSGC Premises

Location Details: _____

Responsible Zone _____ Zonal HSE Team Leader _____

Region _____

Particulars of Affected Person(s):

Serial No		1	2	3	Details of Affected Asset (if any)
Name(s)					
Employee ID(s)					
Designation					
Type of Employment	Permanent				
	Contractual				
	Contractor				
	Visitor				
	Other				
Age					

(Note: For further details additional page may be used)

Incident Type:

Fire Explosion Vehicular Accident Asset Damage Work Related Injury

Theft Sabotage Natural Disaster Gas Leakage Other: _____

Incident Consequences:

Fatality SSGC Hospitalization Asset Damage First Aid Other _____

Other

Incident Classification:

Major Minor Near Miss

Incident Detail:

MIR

43

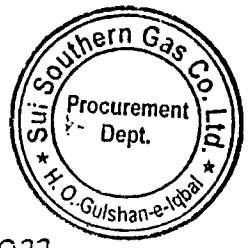

 SSGC HSE&QA Department	IMS FORM	SSGC-IMS/IAM-F-02
	Incident Investigation Form	
	Revision 01	
Issue Date: Aug, 2021		

Incident Notification Form Ref. No.		Incident Detail (Brief)
Incident Date		
Investigated by		

BACKGROUND INFORMATION:

ROOT CAUSE ANALYSIS:

CONCLUSION:

RECOMMENDATION OF CORRECTIVE AND PREVENTIVE ACTIONS		
Recommended Actions	Action by (whom)	Action till (date)
1.		
2.		
3.		
4.		

Is risk assessment required for the corrective actions? If yes, please mention the serial numbers for the recommended actions:

Incharge HSE&QA

NOTE:

1. Please include sketch / photo where ever required to explain the accident scene / conditions
2. Additional pages can be used for mentioning other details
3. Transmission/Distribution department must submit the quantity of gas loss in case of any gas leakage or sabotage

MR

44

M-F-02

 SSGC HSE&QA Department	IMS FORM	SSGC-IMS/IAM-F-03
	Near Miss Notification	
		Revision 00
		Issue Date: Aug, 2019

Personnel Detail (Who Witnessed the Near-Miss):

Category/Type: Unsafe Act Unsafe Condition

Name: _____

Executive / Employee No.: _____

Designation: _____

Department: _____

Location / Area: _____

Near Miss Detail:

Date: _____

Time: _____

Location: _____

Near Miss Related To:

<input type="checkbox"/> Leakage	<input type="checkbox"/> Equipment
<input type="checkbox"/> Slip / Trip	<input type="checkbox"/> Chemical
<input type="checkbox"/> Falling Hazard	<input type="checkbox"/> Biological
<input type="checkbox"/> Fire	<input type="checkbox"/> Transport
<input type="checkbox"/> Electrical	<input type="checkbox"/> Spill
<input type="checkbox"/> Physical	<input type="checkbox"/> Other _____

Brief description of what you saw! (max. 100 words):

Attach Picture: No file chosen

MR

45



1. PURPOSE

The purpose of this procedure is to define a frame work for identification of emergency situations which arise in company operations and for developing emergency preparedness and response plans to mitigate and manage risks arising from such situations or events. The Procedure defines requirements for business continuity planning post emergency situations to bring the business on-line.

Purpose of the procedure is to

- Formulate plan, responsibilities and actions to be taken to handle any emergency situation.
- Identify potential emergency situations and response plans to minimize or avoid actual & potential hazards of any emergency situation.
- Define mechanism and frequency to test plan so as to ensure preparedness and effectiveness of emergency response system.

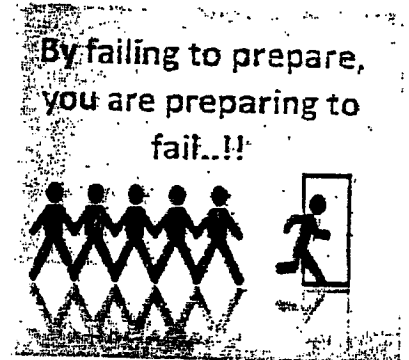

2. SCOPE

This procedure is applicable to all locations of SSGC, its employees and any visitor physically present at the location of emergency site. Due to variations in nature of operations, various departments/sections have developed their own ER Plans catering for their strategic, operational and physical requirements. The same includes HSE emergencies arising from company's day to day operations in terms natural calamities, fire, major incidents, with loss in our operations, major environmental damage, external terror or bomb threats, public unrest, war and etc.

3. DEFINITIONS

- Emergency Situation:** An abnormal situation that calls for immediate and urgent actions for safeguarding life of persons, protecting buildings, machines, vital installations and other assets.
- Rescue:** It refers to responsive operations that usually involve the saving of life or prevention of injury during an incident or dangerous situation.
- Emergency Response Organization (ERO):** It is a group of people, in each section (such as HO, Headquarters etc.), who prepare for and respond to any emergency incident, such as a natural disaster or an interruption of business operations.
- Emergency Response Centre (ERC):** ~~It is a room suitably equipped to handle any potential emergency situations. All emergencies are to be reported here.~~
- First Aid:** It is the provision of initial care for an illness or injury. It is usually performed by non-expert, but trained personnel to a sick or injured person until definitive medical treatment can be accessed.
- Assembly Areas:** If an evacuation to the outside is appropriate, the nominated assembly areas for personnel shall be far enough away from the building, structure or workplace to ensure that, where practicable, everyone is protected from falling glass and other objects.
- Emergency Evacuation:** It is the immediate and rapid movement of people away from the threat or from the place of the hazard.

4. RESPONSIBILITIES

Responsibilities for the particular department/personnel are identified in the response plans prepared by various departments and sections. General responsibilities for Emergency response organization are as under:

- Rush to the area of incident without any delay.
- Immediately assess the situation and initiate the remedial actions.
- Call the fire brigade & other emergency services like ambulances if required.
- Ask/inform all personnel present within premises, using megaphone or any other means, for complete evacuation if situation goes out of control.
- Inform all to go back to their work places using megaphone or any other suitable means when the situation comes under control and the area is free from any hazard.

5. PROCEDURE

The HSE&QA In-charge and department heads shall ensure that all emergency situations are identified during risk assessments performed and emergency response plans are implemented within the departments. They shall also ensure that all employees are made aware of their emergency situations and how to respond during a real emergency. They shall ensure that employees including emergency team members in their respective departments are trained to respond to emergencies and mitigate risks arising out of real emergencies. Some of the potential emergency situations that might occur in SSGC along with the response plans are listed below. Sequence of actions for any response specified on each section's ER plan may change depending upon the emergency situation.

6. Emergency Considerations

The following areas of needs to be given consideration while identifying potential emergency situation but the same need not be limited to these areas:

- Fire & Explosion
- Heavy Spillage of Toxic/flammable chemicals or leakage of gas
- Heavy rain/ flood
- Earth quake
- Bomb threat
- Building & office lockdown/shelter in place
- Active shooter/hostage situation

6.1. Fire & Explosion

In case of fire & explosion each personnel present within the premises must act as per but not limited to the following instructions:

- a. Give voice alarm - FIRE! In case of fire for all immediate employees in the area.
- b. Push the nearest located call point button in case of fire (if present).
- c. Immediately inform Emergency Response Organization through phone or in person.
- d. Try to control the fire by using fire extinguishers. Use fire extinguisher only if you have been trained.
- e. Remove all explosive, inflammable and poisonous materials away to the maximum possibility.
- f. Shut off main valves of gas and circuit breakers.
- g. Stay away from the fire in case it is not controllable.
- h. Report to the designated Assembly Point away from the scene of fire / explosion if asked by Emergency Response Organization through emergency exits and wait for the further instructions.



6.2. Heavy spillage of toxic/flammable chemicals or leakage of gas

In case of heavy spillage of toxic/flammable chemicals or heavy leakage of Gas each personnel present within the premises must act as per but not limited to following instructions:

- a. Immediately inform Emergency Response Organization through phone or in person.
- b. Eliminate all ignition sources (sparks/flames/heat) from the immediate areas.
- c. Turn off gas supply from nearest control valve.
- d. In case of gas leakage in confined space, proper measures (opening windows, doors etc.) should be taken to ventilate the gas. Ensure the availability of fire extinguishers.
- e. Stop leaks if this can be done without having any risk.
- f. Do not touch or walk through spilled material.
- g. Prevent entry into waterways, sewers or confined space.
- h. If available wear the Personal Protective Equipment recommended.
- i. Arrange immediate cleaning of spilled chemical by taking suitable precautions

6.3. Heavy Rain / Flood

In case of emergency situation of heavy rain/flood, personnel must remain present within SSGC premises if the situation gets worst outside. In case of water entering in department/office each person must act as per but not limited to the following instructions:

- a. Try to stop water by keeping sand bags.
- b. Protect building, machines, equipment, tools, parts & material.
- c. Shut off Electricity and Gas if necessary.

Following precautions should be taken by the departments/sections, located under rain/flood threat areas:

- a. Ensure no material is placed outside in open area which may be affected by rain.
- b. Ensure proper drainage system at vital installations so that every valve, equipment, electrical board etc. be accessible in case of any emergency.
- c. Sufficient quantity of tarpaulin and rain suit is available to meet the rainy condition.
- d. Keep the drain line open all the time.
- e. All pumps used for draining out the rainy water are in running condition.
- f. Sufficient quantity of sand bags is available to stop entering the water inside, which may be placed in advance if required.

CLASSES OF FIRE			
Class	Material	Examples	Type of Fire Extinguisher to be used
A	Solids	Paper, wood plastic, etc.	• Water
B	Flammable Liquids	Paraffin, petrol, oil, etc.	• CO2 • Dry Powder
C	Flammable Gases	Propane, butane, methane, etc.	• Dry powder
D	Metals	Aluminum, magnesium, titanium, etc.	• Sodium chloride based dry powder fire extinguisher
E	Electrical Apparatus	Short-circuiting, over loaded electrical cables, etc.	• CO2 Fire Extinguisher
F	Cooking Oil & Fat	Animal fat, etc.	• Dry chemical based: Potassium bicarbonate • Wet: Fine chemical mist

6.4. Earthquake

In case of earthquake shocks each personnel present within the premises must act as per but not limited to the following instructions:

- a. Immediately inform Emergency Response Organization through phone or in person.
- b. Immediately Evacuate to Assembly Areas (in open space where you can keep distance at least one half of the height of the building) after the shocks dampen.
- c. Shut off all switches and valves of main supplies of gas and electricity. (If possible)
- d. Maintain your senses, do not let them disperse.
- e. Protect yourself by sitting on side of tables, furniture & under strong structures. Be aware of falling walls, debris, heavy objects and electrical wires.
- f. Stay away from loosely hanging objects that may fall after initial shock and tremors.
- g. Wait for further instructions from Emergency Response Organization.
- h. ERO should keep in touch with the metrological department / media for aftershocks and future forecasts.

MR
48

- e. The Bomb Disposal Department shall be allowed to operate in the company premises as deemed appropriate.
- f. On getting clearance from Bomb Disposal Department normal routine shall be adopted as advised by Emergency Response Organization.

6.5. Bomb Threat

In case of bomb threat each personnel present within the premises must act as per but not limited to the following instructions:

- a. Immediately inform Emergency Response Organization through phone or in person.
- b. Maintain your senses, do not let them disperse.
- c. Report to the designated Assembly Point if asked by Emergency Response Organization through emergency exits and wait for the further instructions.
- d. Bomb Disposal Department shall be called by Emergency Response Organization.
- e. The Bomb Disposal Department shall be allowed to operate in the company premises as deemed appropriate.
- f. On getting clearance from Bomb Disposal Department normal routine shall be adopted as advised by Emergency Response Organization.

6.6. Building or Office Lockdown/shelter-in-place

If a situation calls for building or office lockdown, the personnel present within premises should act as per but not limited to following instructions:

- a. Remain calm and stay with your colleagues.
- b. Try to stay in pairs.
- c. Do not leave the room and/or building under a lockdown situation until asked otherwise.
- d. Keep quiet and away from doors and windows.
- e. If a gunshot is heard, lay down on the floor and shield under/behind furniture as much as possible.

Take care:
 Don't try to be a hero in emergency situations; do not place your own life or health or that of others in danger. Be prepared for the unexpected!

6.7. Active Shooter/Hostage Situation

In case of shooter/hostage situation each personnel present within the premises must act as per but not limited to the following instructions:

- a. If it is safe to do so, exit the building; if not, lock or barricade yourself inside a room.
- b. Turn off lights, cover and lock the windows, and lay on the floor.
- c. If the shooter(s) leave the area, go to a safer place, if possible. Have an escape route/plan in mind, keep your hands open and visible, and follow any instructions given by law enforcement.
- d. Call the Police/Rangers when it is safe to do so. Remain calm, use a quiet voice, and provide as much information as possible (your name and location, details about the shooter(s) - appearance, weapons, etc.). If you can't speak, leave the line open so the responding authority can listen and try to pinpoint the location.
- e. Cooperate and negotiate with the shooter, in order to buy as much time as possible until the rescue team reaches.

7. EMERGENCY NUMBERS

In consideration of the emergency numbers to be included in the emergency plan, the following should be taken into account:

- Fire brigade/civil defense or equivalent.
- Police.
- Ambulance service.
- Hospitals/Clinics.
- Mutual aid agreements/neighbors.
- Environmental protection agencies.
- Key company personnel.

Integrated Management System

MR

49



is deemed by

8. EVACUATION

All Emergency evacuation routes/doors should be accessible at all times. No hindrances should be placed in the route. All employees should be familiarized with the evacuation routes of their premises.

All employees should immediately evacuate their premises and assemble at the assembly areas (identified by each section). During evacuation following instructions should be followed.

- a. Take only keys, wallets and essential belongings with you.
- b. Leave the building/premises immediately, do not try to investigate the source of the emergency.
- c. Walk, don't run, to the nearest exit.
- d. Use stairs, not elevators.
- e. Assist people with special needs.
- f. As you make your way out, encourage those you encounter to exit as well.

9. THINGS TO BE EVACUATED

In case of emergency, evacuation should be carried in the following order:

9.1. Personnel

Those personnel who do not have sound health such as patients of Heart, Asthma and physically/mentally disabled people are to be evacuated on priority basis.

9.2. Raw Material

Raw material which is explosive, inflammable and poisonous must be removed. Similarly, important lightweight items that are easy to carry must also be removed.

9.3. Documents

Important records and files must also be removed.

9.4. Equipment

Cash Lockers, Computer Sets, External Hard-drives, Expensive Tools and Fixtures must also be removed.

10. TESTING AND EXERCISES

Testing and exercise of the emergency response plan should be conducted at each location of SSGC to evaluate the effectiveness of the preparedness plan. The record and observations of the exercise should be recorded on Emergency Drill Form (SSGC-IMS/ERP-F-01).

Each section should nominate the person who is responsible to periodically conduct the exercise. The frequency and type of drill at each location should be as below:

Location	Type of Emergency Drill	Frequency
a. Head Office b. Regional Offices c. Billing Offices d. P&C Offices e. Store (all locations)	Evacuation and Mock Emergency Drill (all employees)	Six Monthly
f. KT (Transmission) g. Distribution (Zonal and Sub-zonal offices)	Fire Fighting Drill by Emergency Response Team	Six Monthly

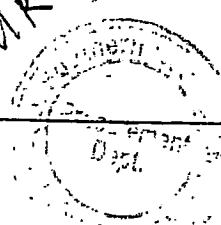
MR

 50

Meter Manufacturing Plant	Evacuation and Emergency Mock Drill (all employees)	Six Monthly
	Fire Fighting Drill by Emergency Response Team	Quarterly
Headquarter Stations	Evacuation and Emergency Mock Drill (all employees)	Six Monthly
	Fire Fighting Drill by Emergency Response Team	Monthly

11. AVAILABILITY AND MAINTENANCE OF ER EQUIPMENT:

Zonal HSE team leaders ensure that emergency detection and response equipment are identified, available and properly maintained in their respective zones. A joint inspection will be carried out periodically to verify the efficacy of ER Equipment. The record shall be maintained on Inspection and Monitoring of ER Equipment Form (SSGC-IMS/ERP-F-02). Each zonal HSE team leader shall maintain record of their respective zone and share with In-charge HSE&QA as and when required. The need for the emergency response equipment is determined by considering the hazards and associated risks with the particular location/operation/equipment/installation etc. The response equipment usually include but are not limited to:

- a. Fire extinguisher.
- b. Fire hydrant/hose/bucket/water pump.
- c. Smoke/gas detectors.
- d. Communication equipment. (Mega phones, Alarm systems, walkie-talkie etc.)
- e. First aid box.
- f. ER vehicles/Ambulance.
- g. Breathing apparatus.
- h. Emergency lights.
- i. Hammer/Axe/shovel/ropes etc.

Frequency of inspection and monitoring of ER Equipment will be as per table given below. However, if situation warrants, this frequency can be changed on the instructions of In-charge HSE&QA or Zonal HSE team leader.

Location	Frequency
a. Head Quarter Stations b. Meter Manufacturing Plant c. K.T (Transmission)	Monthly
a. Head Office b. Regional Offices c. Billing Offices d. P&C Offices e. Store (all locations) f. Distribution (Zonal and Sub-zonal offices)	Quarterly

12. DOCUMENTED INFORMATION:

Record No	Record Name	Maintained by	Retention Period
SSGC-IMS/ERP-F-01	Emergency Drill Form	HSE&QA Department	3 Years
SSGC-IMS/ERP-F-02	Inspection and Monitoring of ER Equipment Form	HSE&QA Department	3 Years

MR

51

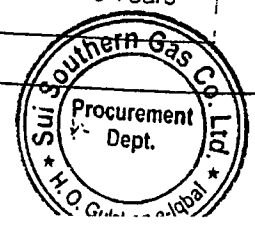

Six Monthly

 SSGC HSE&QA Department	IMS FORM	SSGC-IMS/ERP-F-01
	Emergency Drill Form	
	Revision 01	
Issue Date: Aug, 2021		

Zone	Region	Location	Date
------	--------	----------	------

Type Of Emergency Drill

- Fire and Explosion
 Heavy spillage of toxic/flammable chemicals
 Heavy gas leakage
 Earthquake
 Bomb Threat
 Other :

Observations

S.No	Description	Time	Comments
1	Emergency Siren rang at		
2	Evacuation started at		
3	Last person reached at the assembly point		
4	Firefighting/Bomb disposal squad/other interested party reached at site		
5	Emergency under control at		

Total time of Drill (minutes):

Additional Observations (if any):

Assessment

S.No	Description	Yes	No
1	Emergency responders were present at the site		
2	Employee were properly instructed		
3	Behavior of employees was satisfactory		
4	Evacuation route was satisfactory		
5	SSGC firefighters were well trained		
6	Firefighting equipment were up to the mark		
7	Response of the medical staff was satisfactory		

Overall Assessment:

Satisfactory Unsatisfactory

S.No	Corrective Actions/Improvements Required	Responsibility	Target Date

Security Services Representative		HSE&QA Representative	
Name	Signature	Name	Signature

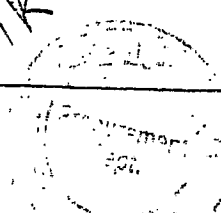
MR

 SSGC HSE&QA Department	IMS FORM	SSGC-IMS/ERP-F-02
	Inspection and Monitoring of ER Equipment Form	
	Revision 01	
Issue Date: Aug, 2021		

Zone	Region	Location	Date
Type Of Equipment <input type="checkbox"/> Fire Extinguisher <input type="checkbox"/> Fire Hydrant/Water Pump/Buckets/Hose <input type="checkbox"/> Smoke/Gas Detector <input type="checkbox"/> Emergency light <input type="checkbox"/> Ambulance <input type="checkbox"/> First Aid Box <input type="checkbox"/> Communication Equipment <input type="checkbox"/> Other :			
CHECKLIST			
S.No	What to check	Yes	No
Fire Extinguisher			
01	Fire extinguishers are in operable condition and not expired.		
02	Pipe and nozzle do not have cracks.		
03	Lever and lever pin are in place and locked.		
04	All extinguishers are clearly visible and accessible.		
Fire Hydrant/Hose/Bucket			
01	No leakage in fire hydrant system.		
02	Hydrant valves are properly lubricated and operational.		
03	Hose pipe is rolled and properly placed. Nozzles are attached at the end.		
04	Fire buckets are maintained and adequately filled with sand		
First Aid Box			
01	All necessary/required medicines are available in First Aid box.		
02	Medicines are not expired and valid for use.		
Smoke/Gas Detector			
01	Alarms and Smoke/gas detectors are properly functioning.		
Other Equipment (if any)			
01			
02			
S.No	Observations	Recommendations	
1			
2			
3			
Additional Comments (if any):			
Security Services Representative		HSE&QA Representative	
Name & Designation	Signature	Name & Designation	Signature

MR

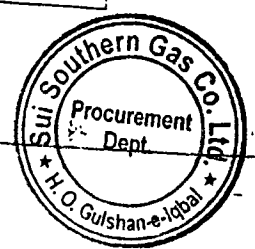

1. PURPOSE

The HSE&QA guidelines for suppliers and contractors are developed to assist suppliers/contractors to meet ssgc's hse&qa policies, procedures, commitment & requirements to ensure safety, integrity and quality of goods/services provided.

2. SCOPE

The procedure is applicable to all suppliers and contractors providing goods or services to SSGC whether on SSGC premises or outside SSGC premises.

3. DEFINITIONS

- a. **Contractor:** Is an independent employer/organization who will be responsible to execute jobs agreed with SSGC.
- b. **Supplier:** Is an independent employer/organization that is responsible to provide goods or services.
- c. **Contract coordinator:** Is an executive of SSGC procurement department, who has been delegated/given responsibility and authority from the head of department to initiate and maintain the contract.
- d. **NEQS:** National Environmental Quality Standards.
- e. **SEPA:** Sindh Environmental Protection Agency.

4. RESPONSIBILITIES

4.1 Suppliers/Contractors and Sub Contractors

- a. The contractor must take all necessary safety precautions related to the performance of the contract in order to protect the work site, including all personnel and property of the SSGC, the contractor, all third parties involved.
- b. Suppliers/Contractors are responsible for safety and well-being of their employees.
- c. The contractor will also be responsible to provide relevant safety equipment (PPE) to their workforce where required. Suppliers/Contractors who have their own HSE&QA management system, shall provide details of the same on request.
- d. The contractor shall ensure that all personnel are adequately trained to perform the task assigned.
- e. ~~Supplier/Contractor shall ensure compliance with SSGC policies, procedures and applicable legal and regulatory requirements.~~
- f. The contractor shall adhere to set standards and requirements for environmental protection.

4.2 Contract Coordinator

The contract coordinator is responsible to arrange training sessions/meetings between contractors and HSE&QA department within 10 days of issuance of a letter to proceed.

4.3 HSE&QA Department

- a. In-charge HSE&QA and contract coordinator are responsible to evaluate the capability and competence of Supplier/Contractor regarding HSE&QA.
- b. In-charge HSE&QA is responsible for providing necessary information and training to Suppliers/contractors regarding applicable SSGC's HSE&QA policies and procedures.
- c. HSE&QA department will carry out inspections and audits to ensure safety and well-being of employees and adherence to set standards, technical specifications and guidelines.
- d. In-charge HSE&QA is responsible to highlight critical nonconformances related to HSE&QA. Strict decisions may be taken against any violation/breaches of SSGC's safety policies/procedures/contract terms during the execution of contract.

5. PROCEDURE

- a. The contract coordinator should ensure that this procedure is part and parcel of every contract made by SSGC.
- b. The contract coordinator must notify in-charge HSE&QA to evaluate the capability & commitment of potential suppliers/contractors regarding HSE&QA during technical evaluation phase.
- c. The contract coordinator arranges a meeting between supplier/contractor and HSE&QA department after issuance of letter to proceed. HSE&QA awareness form (SSGC-IMS/GSC-F-01) will be communicated and duly signed by supplier/contractor as well as HSE&QA department.
- d. HSE&QA department will conduct periodic inspection/audit of worksite/supplier facility to identify gaps on issues related to HSE&QA.
- e. The contractor/supplier shall educate and adequately train their employees in order to understand the requirement of this procedure.
- f. Supplier shall adhere to technical specifications provided by SSGC to ensure quality of goods provided.
- g. The contractor shall perform hazard identification and risk assessment related to their activities for the proper implementation of possible controls/personal protective equipment (PPE) or otherwise consult SSGC's HSE&QA department to seek guidance and awareness on risk/hazards related to activity and its possible controls.
- h. The contract is liable to understand and implement "permit to work (PTW), job safety analysis (JSA)" where required. Please refer to risk assessment and management procedure (SSGC-IMS/CRM-02).
- i. The contractors are responsible to dispose of any waste generated during their activities in an environmentally safe & responsible manner.
- j. The contractors must ensure that only trained individuals meeting necessary requirements/skills will carry out the required job.
- k. Any equipment used by contractor during the project must not pose any environmental and/or safety concerns, and should be in accordance with SSGC's safety procedures and NEQS and SEPA set standards.
- l. Any identified hazards discovered by the contractor that is beyond their ability and/or responsibility to fix must be immediately reported to the contract coordinator and HSE&QA department in writing.
- m. The contractors must ensure that the workforce involved must be physically fit and should not carry any contagious disease. SSGC reserves the right to ask for medical examination/tests of any employee. Contractor will bear all expenses incurred during the medical examination/tests.
- n. For contracts related to providing food services/canteen services, medical reports from accredited labs must be submitted to head of administration services department for entire crew once the contract is awarded and annually for following diseases hepatitis B & C, tuberculosis, and chest X-ray.
- o. In case of violations from SSGC safety standards/policies/procedures, actions will be taken to penalize the contractor depending on the severity/recurrence of breaches, as per following matrix:

S. No.	Violation	Action
1	Single Minor Non-Compliance	Verbal warning
2	Multiple Minor Non-Compliance	Written warning
3	Single Major Non-Compliance	Written warning / Stop the work on site
4	Multiple Major Non-Compliance	Written warning / Financial penalization, discontinuation of contract

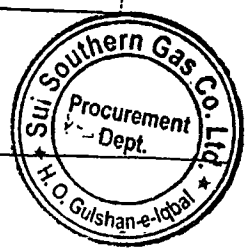

6. ACCESS

- a. Prior to commencement, the contractor will submit a list of their workforce personnel who will be on the site. This data will be updated each time the contractor changes site personnel.
- b. All contractor personnel should park vehicles in the designated parking area. Provisions should be made in advance by the contractor to allow for unloading of equipment and materials inside the facility property. No vehicles shall remain inside the building except for unloading tools or equipment and vehicles will be subject to search and inspection upon exit.
- c. A written pass by the SSGC representative is required in order to remove tools equipment or material from SSGC property. Toolboxes, lunch box bags, etc., are subject to inspection prior to removal. SSGC will prosecute any person, or persons caught removing SSGC property from the premises.
- d. All contractor personnel should enter and leave premises through the main gate, and will be required to sign in and out upon entering and exiting the property. Security will issue an ID badge to each person upon sign-in and at the beginning of each day all contractors must receive a new badge from security.
- e. Contractor employees must stay in their assigned area(s) at the job site and not visit other areas or make any adjustments to any piece of equipment or device unless authorized to do so by an authorized SSGC representative. Failure to abide by this work rule will result in immediate dismissal from the facility and including prosecution.
- f. Each zone maintains secure work areas with limited access at all times. No one is permitted to override any security device for convenience. If access to a secured area is required contact the SSGC representative for authorization. At no time should contractor or subcontractor employees enter the area without prior authorization.
- g. Any work not performed during normal business hours must be approved in advance by the SSGC representative.
- h. All contractor employees will go through contractor safety/induction training upon initial work at SSGC and annually thereafter. A copy of authorized (current) personnel for contractors will be updated and kept at guard shack.

6.1 Tools and Property

- a. For any situation in which the Contractors activity may endanger product quality such as: drilling, welding, removing ceiling tile or any other job which creates metal fragments, shavings or dirt in exposed product of manufacturing equipment areas, approval must be made through the SSGC representative and conditionally approved by the ZTL or representative before work is to commence. The Contractor must abide by conditions established by the Zonal Team Leader or representative to protect the equipment.
- b. Soliciting, selling of any merchandise, gambling or distribution of literature for any cause is forbidden on SSGC property.
- c. Use of company telephones is restricted, unless prior approval is attained from the SSGC representative. Pay telephones are not available.
- d. Horseplay, throwing any object and scuffling are dangerous and forbidden.
- e. Cameras of any kind are not permitted in SSGC work site unless prior written approval is attained from SSGC representative.
- f. Guns, knives or any other weapons are NOT allowed on company property in any case.
- g. SSGC expects all contractors and subcontractors to maintain a drug-free and alcohol-free workplace. Contractors shall maintain a substance abuse program that includes post-offer and for-cause testing. It will be the responsibility of the Contractor Management to inform their employees and subcontractors that the use of, or evidence of use of, intoxicating liquor or illegal drugs are prohibited at all times while on Zone property. Reporting for work under the influence of alcohol or drugs will not be tolerated. SSGC management reserves the right to remove any contractor or subcontractor employee from Zone property who is believed to be under the influence of alcohol or drugs. It will be the contractor's responsibility to enforce these rules.

MR

56

- h. Contractor activities are prohibited in overhead areas of the Zone during the times of production or otherwise that may pose a hazard to personnel or product/material. Deviation from this section will be permitted only with the prior consent of the SSGC representative and affected area is isolated and marked off.
- i. Contractor material will not be shipped directly to the Zone without approval of the SSGC representative.

6.2 Quality Assurance and Personal Hygiene

While working on SSGC premises or at any worksite;

- a. All persons shall maintain a high degree of personal cleanliness, conforming to the same SSGC standard as SSGC employees.
- b. Pens, pencils, tools and supplies must be carried in a secure manner to eliminate the possibility of product contamination or adulteration, (i.e., nothing is to be carried in shirt pockets, lapel, and etc.).
- c. Appropriate PPEs must be worn by all personnel, including dress as appropriate. Contractor is responsible to provide PPE to their workforce.
- d. Proper clothing must be worn at all times. No tank tops, cutoff shirts, or short pants will be allowed. Jewelry and rings are safety and contamination hazards and are not to be worn in working areas.
- e. Persons with suspected communicable diseases, respiratory infections, infected open cuts, sores or skin abrasions will not be permitted to work in any area that could result in contamination of SSGC personnel.
- f. The use of tobacco in any form is prohibited at all times except in the designated Smoking areas.
- g. Chewing gum, candy, storing lunches, eating or drinking beverages are not permitted in or adjacent to the SSGC premises and storage areas. There will be a designated area for contractors to eat. (Cafeteria)
- h. In the event that there are open tanks, or exposed product/materials, containers or storage, the contractor must erect temporary partitions to eliminate the possibility of any foreign material. (This shall include: grinding, cutting, core drilling, masonry work, jack hammering, chipping, metal drilling, pipe threading, wiring, welding and other hot work, etc., where any dust, mist, chips or other debris may be generated.)
- i. The use of containers, boxes, cans, jugs etc., for holding or storing parts, lubricants, solvents or construction material is strictly prohibited.
- j. The contractor is responsible to notify the SSGC representative immediately if foreign material used or generated by the contractor's activity, was accidentally spill into the zone area/ SSGC premises.
- k. Contractor will follow 'Spill Response Procedure' of SSGC in case of any spill occurred.

7. CONTRACTOR SAFETY REQUIREMENTS

7.1 General Safety Rules

- a. All applicable Occupational Safety and Environmental regulations must be followed.
- b. Contractors shall supply to their personnel and to the SSGC representative: emergency contact SSGC, phone numbers, and pager numbers as well as emergency procedures appropriate to their on-site work.
- c. Contractors shall provide the SSGC representative with a current copy of their Safety Program including: Confined Space Entry, Lockout/Tagout, and Hazard Communication procedures (if applicable) and associated training certificates.
- d. The Contractor shall supply all required first aid supplies and safety equipment to support his/her personnel.
- e. Contractors are responsible for providing all required Personnel Protective Equipment (PPE). Contractor employees and subcontractors are required to adhere to all established and/or posted PPE requirements while on SSGC property. Industrial grade safety shoes and safety glasses with side shields are required to be worn at all times. Hearing protection in designated areas.
- f. Only SSGC personnel may operate any valve, electrical switch or other equipment connected to operating sections of the Zone unless prior authorization has been obtained from the SSGC representative. Lockout/Tagout is the standard for energy isolation and MUST be adhered to at ALL times with no exceptions. Contractors are responsible for using their own locks and tags for completing their lockouts. In addition, SSGC personnel may initiate we/they lockout system to ensure compliance.

MR

57

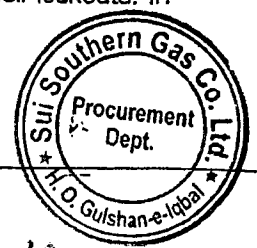

- g. Contractor, contractor employees or subcontractors are NOT authorized to dismantle, shut down, or otherwise make ineffective any fire protection device or system. This requires a special permit obtained by the Zonal Team Leader.
- h. Materials, tools, equipment and supplies will be stored neatly and safely so as not to obstruct roadways, walkways, stairways, emergency doors etc., or allow any condition which may be a potential safety or fire hazard. No tools or materials should be left on steps, walkways, platforms elevated equipment, pipes or overhead areas.
- i. Materials are not to be thrown or dropped from scaffolds or other overhead areas.
- j. Fire lanes and aisles to firefighting equipment are to be left unobstructed at all times. Contractors are to provide fire extinguishers for each welding and burning operation and complete HOT WORK PERMITS.
- k. Material should not have been kept in such a way to block access to fire extinguishers, fire doors, hydrants or manhole covers.
- l. All electrical equipment must be properly grounded.
- m. Any lights carried into and used in a hazardous location must be explosion-proof type and suitable for use in the hazardous area involved.
- n. Use of explosive actuated fastening tools should be used according to the manufacturer's safety guidelines.
- o. All compressed gas cylinders must be supported and secured standing upright according to Pakistan standards. When hoses and valves are removed from cylinders, a protective cap is to be installed on all tanks whether empty or full. Acetylene cylinders, when in use must have a wrench in place.
- p. Areas where overhead hazards, excavations or other unsafe conditions exist must be properly blocked off with appropriate warning signs. In the case of an excavation, barricades must be provided. In reference to night excavation projects, night lights shall be provided by the contractor.
- q. In the event an oil, gas, vapor or other harmful volatile release is caused or discovered, the contractor and/or his employees shall report it at once to the nearest SSGC office and request for further actions immediately.
- r. Vehicles in Zone are required to adhere to the declared speed limit.
- s. Any contractor, contractor employee or subcontractor violating Zone area safety or security rules shall be subject to immediate dismissal.

7.2 Accident Reporting.

- a. Accidents occurring in Zone jurisdiction must be reported immediately to the SSGC representative.
- b. In the event of a fire, medical or other emergency, contractors are required to notify zone security or the SSGC representative immediately. When providing notification give all pertinent information, including your SSGC, location, and emergency situation involved.
- c. All contractor injuries requiring medical assistance beyond basic first aid must be reported in writing with a full investigation within 24 hours of the occurrence (Contractor Accident Investigation Form). This report must be submitted to the SSGC representative for forwarding to the HSE& QA Department.
- d. All contractors and subcontractors must maintain their own OH&S required document/record.

7.3 Confined Space Entry

- a. The SSGC representative will notify the Contractor prior to being hired, if the work will involve entry into confined spaces. The form included in documents will be used to make this notification.
- b. All Contractors who conduct confined space entries must adhere to the SSGC confined space entry requirements.
- c. At no time shall a contractor, contractor employees or subcontractors enter a confined space in Zone without specific authorization from the SSGC representative. Failure to adhere to this policy will result in immediate dismissal.
- d. All contractors are required to keep and maintain their own equipment for confined space entry.
- e. In the event of a confined space entry by contractors, their employees or subcontractor, a standby rescue team must be assembled in Zone assembly area. This rescue team may be SSGC personnel or contractor personnel, however, all arrangements must be made and documented prior to entry.
- f. All contractors and subcontractors who enter a confined space, serve as entry supervisors or rescue team members must have the appropriate training and certification according to the Zone requirements. Copies of all training certification documents must be provided to the SSGC representative & HSE&QA Department.

Integrated Management System

MR

58

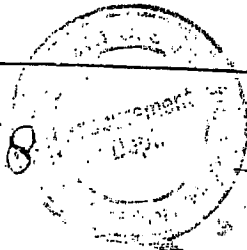

Shut down, or
fined by the
SSG.

7.4 Cranes and Overhead Work

- a. All Contractors who conduct work at height, e.g., all work occurring at an elevation above 72 inches without a standard railing must adhere to the SSGC Work at Height Requirements.
- b. All work at height requires the use of a safety harness. All safety harnesses, lanyards and related fall protection equipment must comply with applicable local and ANSI requirements.
- c. All contractor employees working in forklift baskets, scissors or man lifts are required to wear a safety harness.
- d. Working with cranes and derricks require compliance with the SSGC Lifting Equipment requirements and the equipment manufacture's recommendation. Zones and generally accepted practices for safely operating and rigging procedures and methods must be used.
- e. All cranes used on company property must be inspected once per shift and any problems identified must be corrected prior to crane usage. Copies of all inspection records must be provided to the SSGC representative upon request.
- f. In the event that overhead work must occur in locations within the Zone where high voltage, overhead power lines are located, all cranes and overhead lifting devices must maintain a 10-foot clearance. In the event proper clearance cannot be maintained, the power lines are to be de-energized and locked out prior to performing work. In the event the lines must be de-energized, prior approval must be given by the SSGC representative.

7.5 Hazardous Energy Control (Lockout) Procedures

- a. All contractors, contractor employees and subcontractors must comply with the SSGC Energy Control Requirements.
- b. In the event that a contractor, contractor employee or subcontractor servicing or entering a piece of machinery where the danger of injury exists from unexpected energizing of the equipment or unexpected release of stored energy, the contractor or contract employee must disconnect the source of energy and lock/tag out this equipment before beginning work.
- c. In the event that SSGC employees or other unknown persons have locked/tagged out equipment, the contractor is not to remove the lock/tag or energize the equipment. Likewise, the contractors are not to LO/TO any machinery without approval of SSGC representative or remove LO/TO without communicating to all affected associates.
- d. Contractors are required to supply their own lockout locks, tags and hasps.
- e. In the event that a contractor or subcontractor has de-energized and locked out a piece of equipment, the equipment specific lockout procedure must be adhered to. A contractor, contractor employee or subcontractor can acquire the specific equipment lockout procedures from the SSGC representative.
- f. The lockout tag used by the contractor must have the contractor's phone number and a person name, SSGC to be contacted concerning the lockout.

7.6 Zone Equipment and Tools

- a. Contractors will provide their own equipment to their employees.
- b. The use of SSGC vehicles and equipment is prohibited for contractors. Contractors can only acquire this authorization from the Zonal Team Leader. Authorization, when provided, will be documented by use of the Equipment Loan and Indemnification Agreement. Use of all shop equipment is prohibited.
- c. Misuse of SSGC material, equipment or products is prohibited.
- d. The use of SSGC powered industrial vehicles (i.e. forklifts) is strictly prohibited. In the event that SSGC forklifts are required, they can only be operated by certified SSGC employees. There will be no exceptions to this policy. Any contractor, contractor employee or subcontractor who operates an SSGC forklift will be requested to leave the property immediately.
- e. All contractors, contractor employees or subcontractors who operate a powered industrial vehicle in Zone Area must possess a current operator certification.

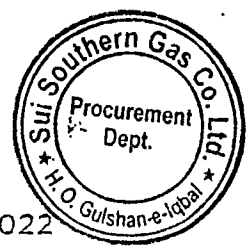
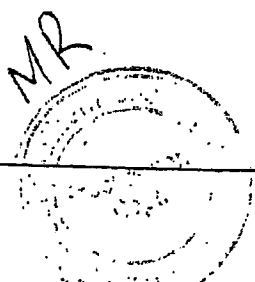

7.7 Hazard Communication

- a. Contractors, contractor employees or subcontractors who bring hazardous chemicals on-site, must prior to bringing them on-site:
 - i. Provide the SSGC representative with a listing of all hazardous chemicals.
 - ii. Property label all containers, adhering to SSGC labeling requirements.
 - iii. Provide the SSGC representative with copies of all SDSs (Safety Data Sheet) for the hazardous chemicals.
- b. The SSGC representative will provide all contractors with a list of hazardous chemicals that the contractor, contractor employees, or subcontractors will come in contact with during the work on Zone property.
- c. At no time should hazardous materials or fuels be left unattended in open containers or unsecured areas overnight, during weekends, or during holiday periods. Temporary storage of such material must be reviewed with the Company representative.
- d. When the use or storage of explosives or other hazardous materials or equipment is necessary for the execution of the work, the Contractor shall exercise the utmost care and shall carry on such activities under the supervision of properly qualified personnel and in conformance with all applicable Zone Requirements and local environmental and safety regulations.
- e. The contractor shall be responsible for all necessary Personal Protective Equipment (PPE), training, and informing their employees of all hazardous substances in use at the job site and of the appropriate safety procedures and policies.

7.8 Emergency Procedures

- a. In the event of a fire, medical or other emergency, Contractors are required to notify zone security or the SSGC representative immediately. Tell the security personnel the location of the fire and any other pertinent information. In the event that Zone security or SSGC representative cannot be reached, evacuate the area and call area/city emergency department as soon as possible.
- b. All contractors, contractor employees and subcontractors are required to follow the predetermined exit routes and emergency evacuation procedures posted at the facility.
- c. All contractors, contractor employees and subcontractors are required to exit the work area/building in the event of emergency alarm activation or if instructed to by an SSGC representative. In the event of an evacuation, contractors are required to go directly to the employee staging area located at guard shack.

7.9 Gasoline and Propane Powered Equipment

- a. Contractors are required to inform the SSGC representative of any propane or gasoline powered equipment that is to be used indoors.
- b. SSGC Management discourages the use of internal combustion engines indoors, and will only permit it when no reasonable alternative means are available to complete the job.

7.10 Temporary Electrical Connections

- a. All wiring & electrical installations are expected to follow National Electric Code practices.
- b. All temporary electrical hook-ups for equipment must be approved by the SSGC representative, prior to installation. All temporary installations must be removed as soon as the task requiring them is complete.
- c. Electrical outlets for portable power tools not a part of permanent wiring of the building should have ground-fault circuit interrupters (GFCI).

MR

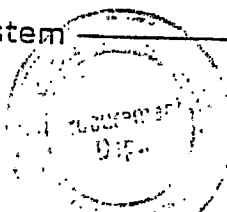

7.11 Cutting, Welding and Other Hot Work

- a. All Contractor and subcontractor employees must comply with the SSGC Cutting, Welding and Other Hot Work procedure.
- b. The SSGC representative will issue the Cutting-Welding-Hot Work Permit after confirming that the necessary precautions have been taken.
- c. The permit is valid for ONE SHIFT ONLY. When the work overlaps with the next shift, the SSGC representative will issue a new permit.
- d. The contractor employee designated as the "fire watch" shall sign the permit after the final check has been made and return the signed permit to the SSGC representative.

7.12 Ladders and Scaffolding

- a. All ladders belonging to the contractor must be labeled with the contractor's SSGC and possess safety feet and meet SSGC Work at Height Requirements.
- b. All ladders used on Zone property must be properly secured.
- c. All scaffolding must be equipped with railings and toe boards.
- d. All "swinging" type scaffolds must be inspected by the contractor and repaired if necessary before use.
- e. All overhead work from a forklift must be conducted from a secured safety cage. Standing on forks or pallets is not permitted.

8. CONTRACTOR ENVIRONMENTAL RULES

SSGC requires that contractors comply with all applicable environmental rules & regulations.

8.1 Non-Hazardous Waste

- a. Construction refuse and debris will not be allowed to accumulate and will be removed daily by the contractor at its expense, unless otherwise negotiated in the contract document.
- b. Contractors shall take ownership of all waste and debris generated from materials they brought to the job site or from demolition activities, and shall dispose of such waste and debris in accordance with all applicable laws and regulations.
- c. Reference to SSGC, The SSGC Company or any of its trademarks shall not be used in any documentation associated with the disposal of such waste and debris.
- d. Contractors shall coordinate with the Zone, whenever practical, to segregate debris or waste which may be recycled or re-used in a safe and environmentally responsible manner.
- e. Worksites may be periodically inspected by the SSGC representative to ensure that the contractor is fulfilling its obligations under its contract. Final payment will be withheld until such time as the worksite and property have had a final inspection and removal of all containers, debris, wastes and materials has been confirmed by the SSGC representative and documentation has been printed that all hazardous wastes have been properly disposed.
- f. For those contractors working outside, it is illegal to dispose of any liquid, including water, onto the ground/outside drain for any reason. All water, provided it was not contaminated, shall be disposed of at a drain inside of the facility.

8.2 Hazardous Materials

- a. Contractors, contractor employees or subcontractors who bring hazardous chemicals on-site, must prior to bringing them on-site:
 - i. Provide the SSGC representative with a listing of all hazardous chemicals.
 - ii. Provide the SSGC representative with copies of all MSDSs for the hazardous chemicals.
 - iii. Properly label all containers, adhering to SSGC labeling requirements.



- b. No hazardous wastes will be placed or discarded into any drain or sewer on SSGC property. Sewers include: process sewers, sanitary sewers and stormwater sewers. Contractors shall use drain covers, dikes or other appropriate means to prevent a potential release into a drain. In the event that material enters an SSGC sewer, the contractor shall notify the SSGC representative immediately.
- c. Contractor is solely responsible for any and all hazardous wastes generated by contractor's activities on the property. All hazardous material/waste generated by contractors must be disposed of in an approved container and properly labeled. It is the contractor's responsibility to properly dispose of all waste and hazardous materials, and remove containers that store or contain any waste or hazardous materials. Such containers/materials shall be removed from SSGC's property daily and shall be properly disposed of by the contractor/supplier in accordance with all applicable Federal, State and Local laws, rules and regulations. No waste, containers, debris, etc., are to be disposed of in SSGC dumpsters by Contractor, without approval from the SSGC representative. At no time should hazardous waste be manifested or labeled with reference to The SSGC Company or any of its zones or subsidiaries without authorization from the SSGC representative or Zone HSE Manager.
- d. The contractor shall assure that all employees dealing with hazardous materials and hazardous wastes have had all legally required training and are familiar with the hazards presented by such wastes or materials.

8.3 Spill Response Procedures

- a. Each contractor is required to have a written emergency response plan to handle spills and releases which may occur during transport, delivery, or use of hazardous materials at the SSGC work site. The contractor must provide a copy of its emergency response plan to the SSGC representative prior to beginning work.
- b. Each contractor must provide and be equipped with appropriate spill response equipment. All contractors, contractor employees or subcontractors who engage in the emergency response of a hazardous material release must have been trained and have the appropriate spills response certification and meet response requirements.
- c. Contractor must provide documentation to verify that it has contracted with at least one reputable outside spill response contractor, that is reasonably agreeable to SSGC, to respond to larger spills or releases which may occur during transport, delivery or use of hazardous materials.
- d. The contractor shall be responsible for appropriate clean-up of spills caused by their activities. Such clean-up will include removal or remediation of any materials impacted by such spill, such as: building materials, soil, groundwater or surface waters, etc.
- e. In the event that a spill or release of contractor's material occurs on SSGC's property and the contractor does not respond to the release to the satisfaction of SSGC, SSGC shall have the right to take any reasonably necessary steps to respond to or remediate such spill or release. The Contractor shall reimburse SSGC for all costs incurred by SSGC to respond to such spill or release.
- f. Spills and releases of hazardous materials must be reported immediately by the contractor to the SSGC representative.
- g. Any spill or release that exceeds an applicable reportable quantity must be reported by the contractor to the appropriate governmental agencies according to applicable laws and regulations. Prior to notifying the responsible outside parties (i.e., governmental agencies), contractor shall first inform SSGC of its intent to report such spill or release.
- h. Contractor is also bound to follow SSGC's 'Spill Response Procedure'.

8.4 Special Circumstances

SSGC acknowledges that, from time to time, specific work regarding hazardous materials investigation or response may occur. Under such circumstances, the contractor shall supply a copy of the Work Plan (WP) and Health and Safety Plan (HASP) to SSGC for review and approval prior to commencing work.

MR
Integrated Management System

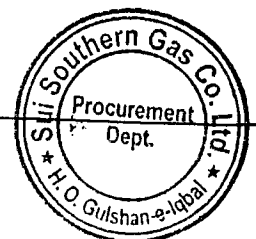
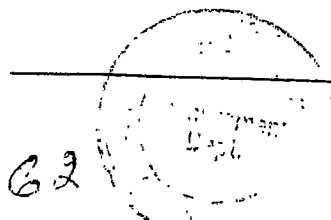

9. CONTRACTOR ACCEPTANCE OF WORK RULES AND REQUIREMENTS

All contractors are required to sign a statement that they have received a copy of this program and have read and understand the program. Each contractor shall sign the following Contractor Acceptance of Work Rules and Requirements form and return it to the SSGC representative. A copy will be kept in the project management file and the Zone's HSE Manager's files.

In consideration of admission to the premises of SSGC, we agree to hold in strict confidence and not to divulge to any other person or entity all proprietary information observed or disclosed by SSGC personnel. This includes information that relates to SSGC's past, present, or future research, development and business activities or any client or customer to whom SSGC provides services and/or materials. We will not remove any document, material, or equipment, nor photograph or record any data without specific written permission from a duly authorized representative of SSGC.

This agreement of confidentiality will terminate only when and as SSGC proprietary information becomes public knowledge.

We have read and understood the visitor agreement and will abide by the document while visiting the SSGC facility as required.

10. CONTRACTOR ACCEPTANCE OF WORK RULES AND REQUIREMENTS

The undersigned hereby acknowledges that we have received a copy of the SSGC Contractor Work Rules. We have read and will be able to abide by the items listed in the SSGC Contractor Work Rules. We understand and agree that any persons and/or contractors who violate these rules will not be permitted to work for SSGC. We also understand that we are responsible for ensuring that all employees working directly for us, as well as any contractor and/or subcontractors that we hire, comply with these rules.

Compliance with the SSGC Contractor Work Rules does not in any way relieve any contractor or person from complying with any applicable Federal, Provincial or local safety, environmental and other regulations which may apply. The work rules are only a compendium of certain legal requirements and Zone policies. They are not an exclusive discussion of any and all legal requirements applicable to contractors and/or suppliers.

The undersigned represents and warrants that we shall comply with all applicable Federal, State and Local laws, regulations and rules while we are engaged to work or perform services for SSGC, including but not limited to any and all OSHA, Federal, EPA, Sindh, and other health, safety, and environmental requirements. In addition, in consideration of SSGC hiring us, we hereby agree to indemnify and hold harmless SSGC against any and all liability, including defense cost and attorneys' fees, arising from or relating to breach of the above warranty and/or any violation of applicable laws, regulations and/or rules.

MR

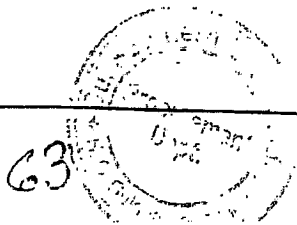

Company _____

Date _____

SSGC (Print) _____

Signature _____

Title _____

SSGC Representative _____

cc: Project Manager File
Zone HSE Manager
Contractor

11. DOCUMENTED INFORMATION

Record No.	Record SSGC.	Maintained by	Retention Period
SSGC-IMS/GSC-F-01	HSE&QA Awareness Form	HSE&QA Department	3 Years

NR

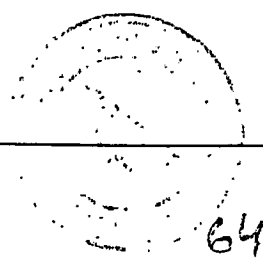

 SSGC HSE&QA Department	IMS Form	SSGC-IMS/GSC-F-01
	HSE&QA Awareness Form	
	(Guidelines for Suppliers and Contractors)	
		Revision 01
		Issue Date: Aug, 2021

Organization Name		Contact name	
		Contact number	
Type of Contractor <input type="checkbox"/> Mechanical Work <input type="checkbox"/> Electrical Work <input type="checkbox"/> Civil Work <input type="checkbox"/> Waste Disposal <input type="checkbox"/> Canteen <input type="checkbox"/> Transport <input type="checkbox"/> Manpower Contractor <input type="checkbox"/> Pipeline Construction <input type="checkbox"/> Third party inspection <input type="checkbox"/> Goods Supplier <input type="checkbox"/> Other:			
Area of Working:			
Contract Coordinator:			
HSE&QA Awareness			
Description		Remarks	
ISO & OHSAS Standards			
HSE&QA Policy			
PPE Policy			
Risk Assessment and Management Procedure			
Incident and Accident Management Procedure			
Emergency Response Procedure			
Technical Specifications/Performance and Testing Criteria			
Remarks:			
Supplier/Contractor Representative		HSE&QA Representative	
I have received and reviewed the SSGC's HSE&QA Requirements and understand that the requirements will be applicable while supplying goods, works or services within company premises or outside company premises. I shall make sure all employees of our company and Sub-Contractor companies understand and agree to the requirements applicable to the activities our company will be performing.		I have met the Supplier's/contractor's representative and provided basic information of HSE&QA Policies and Integrated Management System. The Contractor has shown its commitment in adherence to Company's HSE&QA Policies/procedures/technical specifications /and related requirements to ensure quality, safety and integrity of the goods/services provided.	
Name	Signature	Date	Name

MR



65

PENALIZATION MECHANISM

MR for Service Contracts Only

1. Penalization

SSGC management reserves the right to penalize the service contractors in case of any nonconformance during course of the project (addressed in respective ToR / Tender Documents in detail). Penalization will vary according to severity of nonconformance and mode of penalization is provided in respective Terms of References. SSGC management decides the mode and degree of penalization.

1.1 Penalization mechanism

Following flow chart depicts the mechanism/ hierarchy, which will be followed for the penalization of the contractor. Penalization Form and *Annexure-J-1* can be found below.

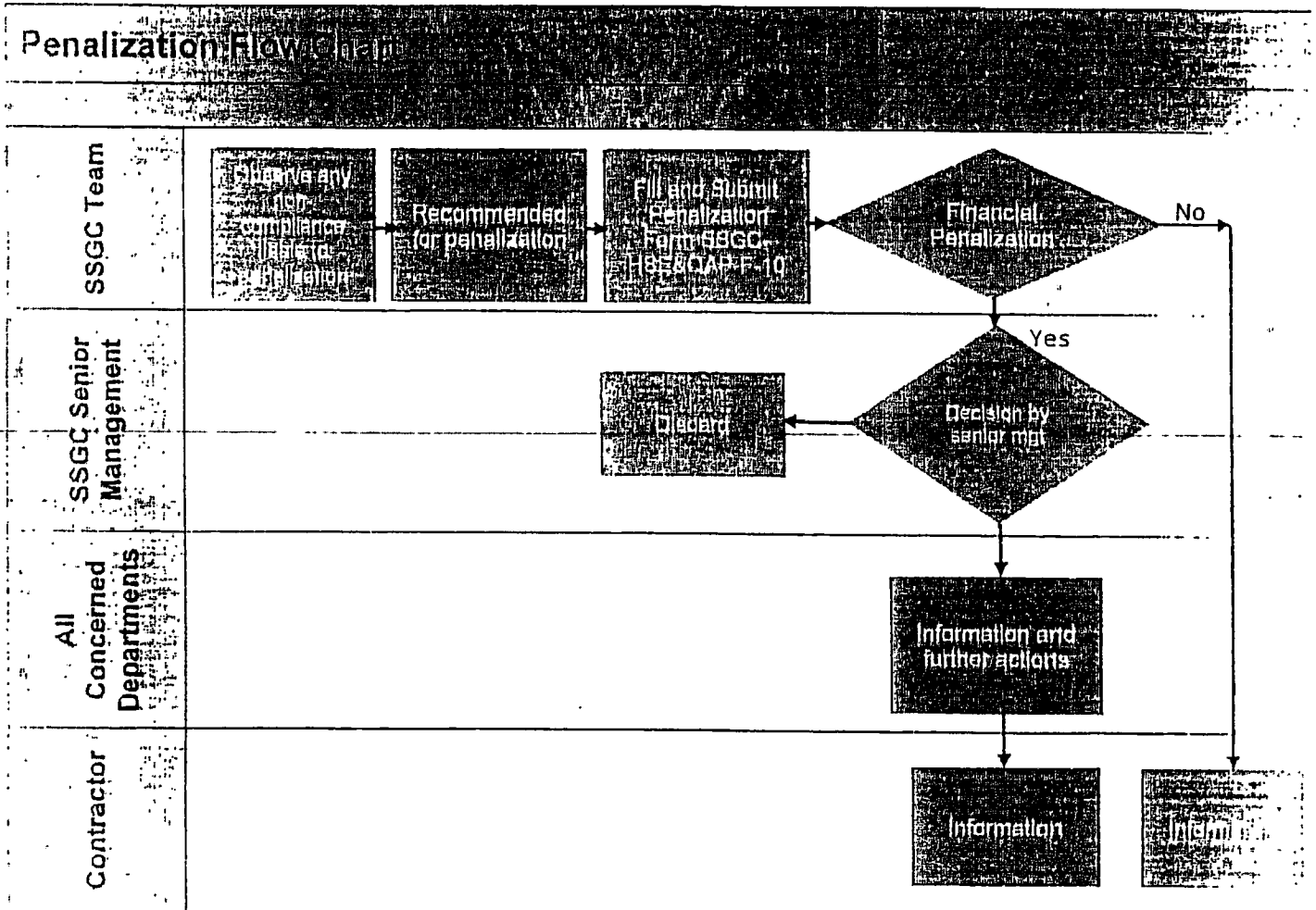

MR
[Signature]

[Signature]

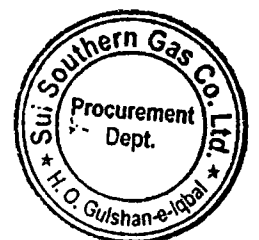
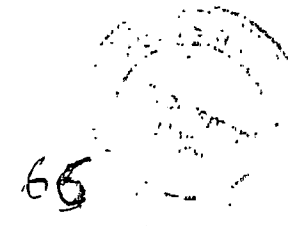

PENALIZATION FORM
for Service Contracts Only

Project	<input type="text"/>	Date	<input type="text"/>
Section	<input type="text"/>	Contractor	<input type="text"/>
User Dept.	<input type="text"/>	Focal Person	<input type="text"/>

Nature of Non-Compliance (As per Annexure J-1)

Mode of Penalization

Initiator	
Name	Signature
<input type="text"/>	<input type="text"/>
<input type="text"/>	<input type="text"/>

Recommended by HSEQA	
Name	Signature
<input type="text"/>	<input type="text"/>
<input type="text"/>	<input type="text"/>

Recommended by User Departmental/Divisional Head

Following Section is applicable ONLY in case of Financial Penalization

<input type="text"/>	<input type="text"/>
DMD (Ops)	DMD (Finance)

Copy to: Procurement/Finance/P&D Department, Contractor
Note. Adequate evidences MUST be furnished along with form by initiator

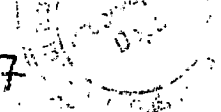
MR *67* 

S. No.	Nature of Non- Compliance	Mode of Penalization
--------	---------------------------	----------------------

HSE

1	PPE related	1 st Time ----- Verbal Warning from site in charge 2 nd Time ----- Written warning / Explanation Letter 3 rd Time ----- Removal of worker from duties
2	Unsafe Act / Unsafe Condition	1 st Time ----- Stop work 2 nd Time ----- Stop work along with written warning letter 3 rd Time ----- Removal from duties.
3	Not reporting any major incidents within the time frame specified in Tender documents / HSE&QA Plan	Financial Penalization up to Rs. 200,000 for each accident
4	No proper tag out/ lockout/ barrication / signage boards and systematic PPE non-compliance as advised by SSGC representative(s) at Site or mentioned in SSGC SOPs, work instructions or ToRs.	1 st time ----- Warning Letter 2 nd time ----- Stoppage of Work 3 rd Time ----- Financial Penalization up to 3% (Max.Rs. 200,000 can be penalized).

Quality

5	Deviation in actual manpower provided vs the manpower (Organogram) submitted in tender documents	Cost of unavailable staff, as listed in TOC or other related documents
6	Non-Compliance related to Quality Parameters outlined in ToR, BOQ, applicable international Standards & Codes and SSGC's SOPs.	Up to 2% of the invoice amount of the billing period

Reporting

7	Non Submission of time bound reports (as mentioned in Tender documents / Construction Plan	Financial penalization up to 2% of the invoice amount of the billing period
8	Unavailability of documents such as drawings, SOP manuals, inspection reports and other Technical data at site office.	Explanation letter
9	Providing wrong / insufficient information in invoicing pertaining to equipment and manpower.	Financial penalization Up to 2% of the invoice amount of the billing period
10	False reporting, misleading information	Financial Penalization up to 3% of the amount of the billing period

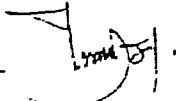

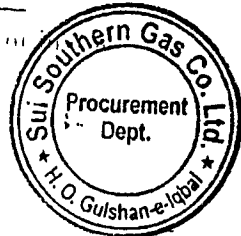
MR
ES



SSGC HSE&QA Department	PENALIZATION MECHANISM <i>for Service Contracts Only.</i>	SSGC-HSEQP-F-10
	MR ANNEXURE J-1	Revision 01 Issue Date: Sep. 2022

Ethics & Conduct

11	Non-cooperation with SSGC team by any staff of Contractor. Non-cooperation includes non-sharing of construction site data, supporting documents, future work execution strategies etc. compliance of Company protocols or instructions related to works given by SSGC's representative(s).	Removal from duties in case the request is made against this non-Compliance Note: Approval will be taken from contract owner i.e. User Departmental Head.
12	Repeatedly (03) absence/Unavailability of site Contractors staff during surprise visits of SSGC teams	Financial penalization (One day salary deduction of entire site staff of audited site)

- Note:
1. Penalization amount will not exceed the 5% of the total contract value.
 2. If Three (03) non-compliance (on any one issue or combination of issues) are issued to any contractor, Management will decide to impose additional penalization (e.g. forfeiting of Performance Bank Guarantee / retention money), termination of contract or temporary blacklist (Blacklisting will be up to one (01) year.
 3. Tender/ Project specific requirements and penalization are outlined in tender documents/ ToR under special requirement section.

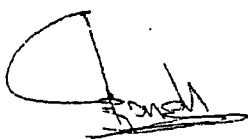
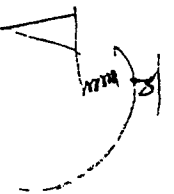

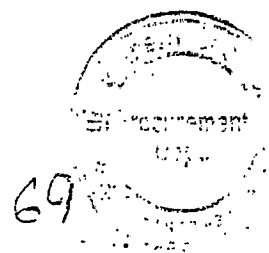
 MR



SSTW-05

Ref No _____

Dated _____

M/s _____

SNTN _____

Address _____

NOTICE UNDER RULE 3(1) OF THE SINDH SALES TAX SPECIAL PROCEDURE (WITHHOLDING) RULES, 2011.

Dear Sir,

Kindly note that we are a withholding agent under the Sindh Sales Tax Special Procedure (Withholding) Rules, 2011, and that we shall withhold and deduct the prescribed amounts of Sindh sales tax against your tax invoices in relation to the services provided or rendered by you to us. We hold NTN/FTN

2. We undertake to deposit the withheld/deducted amounts of Sindh sales tax in the Sindh Government's head of account "B-02384" against a SRB-prescribed PSID/Challan (SST-04 or SSTW-04) in the manner prescribed under the aforesaid Sindh Sales Tax Special Procedure (Withholding) Rules, 2011, and we shall provide you a certificate of deduction-cum-deposit in terms of rule 3(9) thereof.

Signature _____

Name _____

CNIC _____

Designation _____

Date _____

Official seal _____

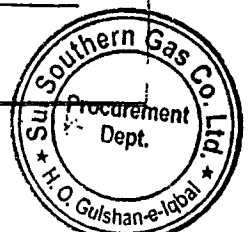
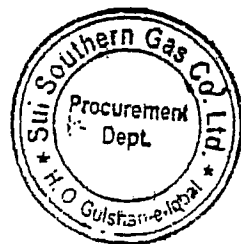



**Sui Southern Gas
Company Limited**

Procurement Department

Standard Advisory to all Bidders

SUB: Sindh Sales Tax Withholding On Services Payment

(Effective from 1 July 2024)

Dear Sir,

Background

Please be informed that:

1. Uptil February 2024, SSGC deducted 20% of Sindh Sales Tax amount from Invoice value payable to a Vendor for services rendered in Sindh & deposit the same with Sindh Revenue Board, while remaining 80% is deposited by the Vendor themselves.
2. From March 2024 – June 2024, SSGC deducted 80% of Sindh Sales Tax amount from Invoice value payable to a Vendor for services rendered in Sindh & deposit the same with Sindh Revenue Board, while remaining 20% is deposited by the Vendor themselves

Amendment in Law

Sindh Revenue Board (SRB) has amended Withholding Rules thereby requiring SSGC to deduct 20% of sales tax amount from Invoice Value.

Revised Procedure for Sindh Sales Tax Withholding

In order to ensure implementation of above amendment, following process is being implemented 01. July 2024:

- 1) 80% Sales Tax to continue to be withheld on 'Past' Invoices only (where Vendor has already deposited 20% Sales Tax in Government treasury provides evidence thereof).
- 2) 20% Sales Tax will be deducted on Current and future invoices (while 80% will be deposited by vendor directly with SRB)

It is needless to mention that only Sindh Withholding Rules have been amended white there is no change in other Rules (income tax withholding Balochistan Sales Tax withholding; etc.)





سوی سدرن گیس کمپنی لمیٹڈ
پروکیورمنٹ ٹیپارٹمنٹ

تمام ٹھیکیداروں کے لئے معیاری ایڈوائزری
خدمات کی ادائیگی پر سندھ سیلز ٹیکس
(۱ جولائی ۲۰۲۲ سے نافذ العمل)

س منظر

مطلع کیا جائے کہ:

1. فروری 2024 تک، SSGC نے سندھ میں فراہم کی جانے والی خدمات کے لیے وینڈرز کی انوائس ویلیو سے سندھ سیلز ٹیکس کی رقم کا 20% کاٹ لیا ہے اور اسے سندھ ریونیو بورڈ کے پاس جمع کرایا ہے، جبکہ وینڈرز بقیہ 80% خود جمع کراتے ہیں۔

2. مارچ 2024 سے جون 2024 تک، SSGC نے سندھ میں فراہم کی جانے والی خدمات کے لیے وینڈرز کی انوائس ویلیو سے سندھ سیلز ٹیکس کی رقم کا 80% کاٹ لیا ہے اور اسے سندھ ریونیو بورڈ کے پاس جمع کرایا ہے، جبکہ بقیہ 20% وینڈرز خود جمع کراتے ہیں۔

قانون میں ترمیم

سندھ ریونیو بورڈ (SRB) نے ود ہولڈنگ رولز میں ترمیم کی ہے جس کے تحت SSGC کو انوائس ویلیو سے سیلز ٹیکس کی رقم کا 20% کٹوتی کرنا ہوگی۔

سندھ سیلز ٹیکس ود ہولڈنگ کا نظر ثانی شدہ طریقہ کار

مندرجہ بالا ترمیم کے نفاذ کو یقینی بنانے کے لیے، 01 جولائی 2024 سے درج ذیل عمل کو نافذ کیا جا رہا ہے:

(1) 80% سیلز ٹیکس صرف 'ماضی' انوائسز پر کٹوتی جاری رہے گی (جہاں وینڈر نے پہلے ہی سرکاری خزانے میں 20% سیلز ٹیکس جمع کرایا ہے اس کا ثبوت فراہم کرتا ہے)۔

(2) 20% سیلز ٹیکس موجودہ اور مستقبل کے انوائسز پر کاٹا جائے گا (جبکہ 80% وینڈر براہ راست SRB کے ساتھ جمع کرائے گا)

یہ واضح رہے کہ صرف سندھ ود ہولڈنگ رولز وائٹ میں ترمیم کی گئی ہے دیگر رولز (انکم ٹیکس ود ہولڈنگ بلوچستان سیلز ٹیکس ود ہولڈنگ وغیرہ) میں کوئی تبدیلی نہیں کی گئی ہے۔

SECTION – IX

DRAWINGS

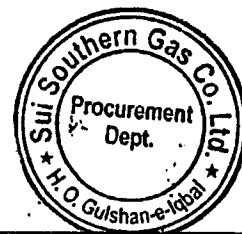

REFERENCES:

FOR GUARD ROOM DETAIL:
REF - C59-BOIP-GUARD-C8004
FOR BOUNDARY WALL DETAILS:
REF- C59-BOIP-BWALL-C9007
FOR UNDERGROUND TANK DETAIL:
REF- C59-BOIP-UGT-C9008

*M.S. J. HADFIELD
C.E.C.O. P.D.C.*

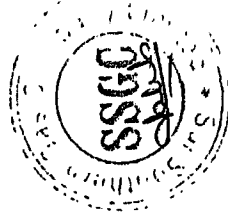

NO	DATE	BY	REVISIONS
1	23-02-2024		

ISSUE	NO	DATE	BY
	1	23-02-2024	

SUI SOUTHERN GAS CO. LTD. BIN GASIM INDUSTRIAL PARK PROJECT			
DRAWING NO.	C59-BOIP-TBS-C9009	ISSUE NO.	1 OF 1
SCALE	AS	SHEET NO.	
FILE NAME	C59-BOIP-TBS-C9009	DATE	23-02-2024
PLANT NO.		PLANT SCALE	1" = 30'
PROJECT NO.		PROJECT SCALE	1" = 30'

TYPICAL DETAIL OF WALL ENCLOSURE FOR TBS-BOIP			
DRAWING NO.	C59-BOIP-TBS-C9009	ISSUE NO.	1 OF 1
SCALE	AS	SHEET NO.	
FILE NAME	C59-BOIP-TBS-C9009	DATE	23-02-2024
PLANT NO.		PLANT SCALE	1" = 30'
PROJECT NO.		PROJECT SCALE	1" = 30'

ASSEMBLY AREA

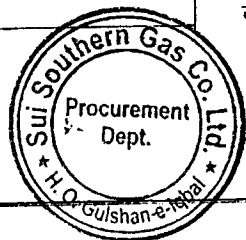
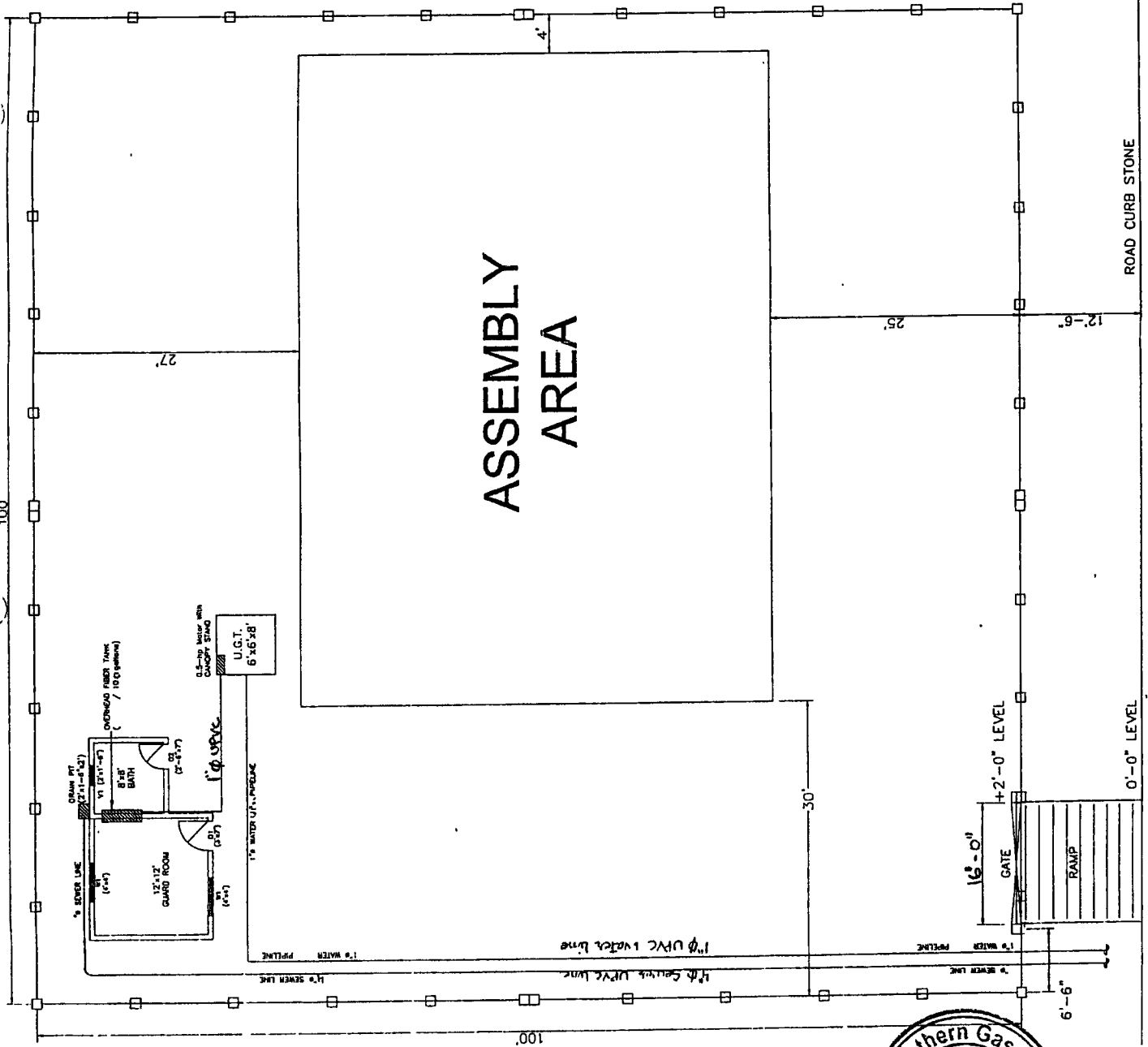

GENERAL NOTES

1. CONCRETE QUALITY TO BE 3000 PSI AT 28 DAYS.
2. ANGLE IRON CONFORM TO STRUCTURAL STEEL ASTM-36A.
3. M.S STEEL BARS TO BE USED OF 80000 PSI YIELD STRENGTH.
4. SULPHATE RESISTANT CEMENT SHOULD BE USED FOR CONCRETE AND PLASTER/MORTAR BELOW PLINTH.
5. ANCHOR BOLT STEEL TO CONFORM ASTM-A307
6. ANGLE IRONS TO BE INSTALLED ON TOP OF BOUNDARY WALLS
7. EXPANSION JOINTS TO BE PROVIDED AT EVERY 50' INTERVAL.
8. STEPS & RAMP SHALL BE PROVIDED ON SITE AT ENTRANCE GATE.

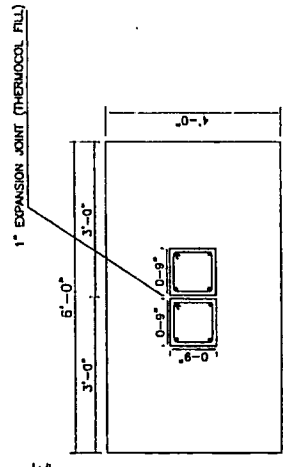
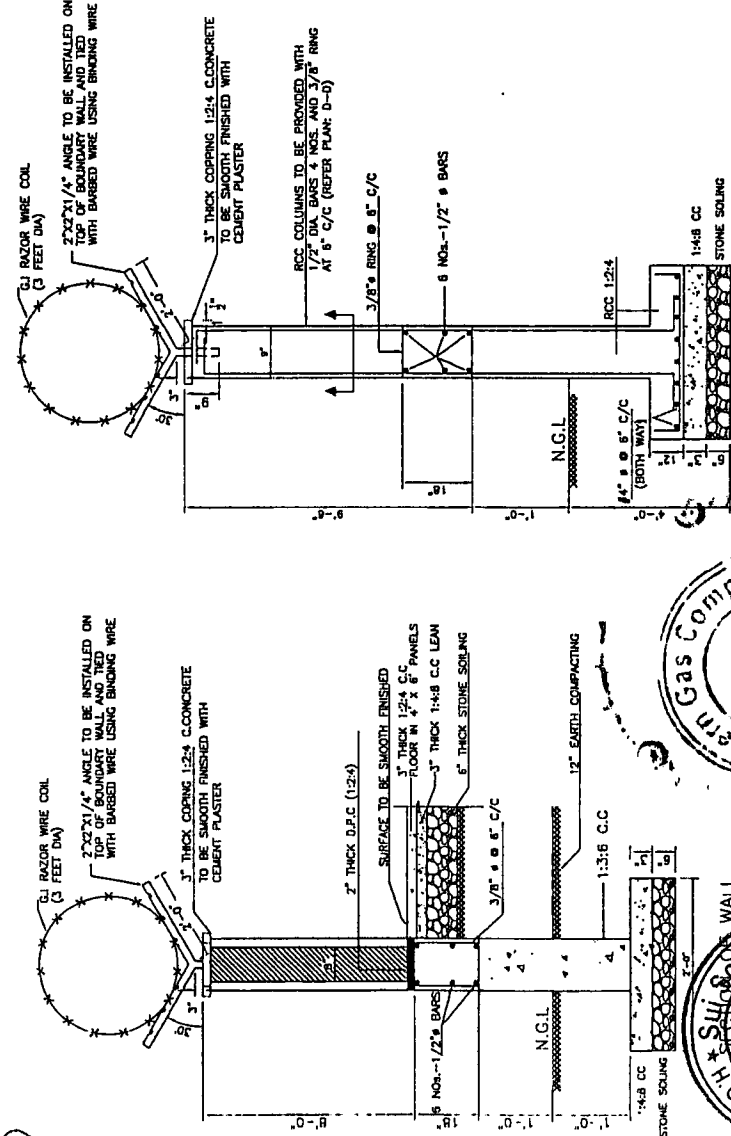
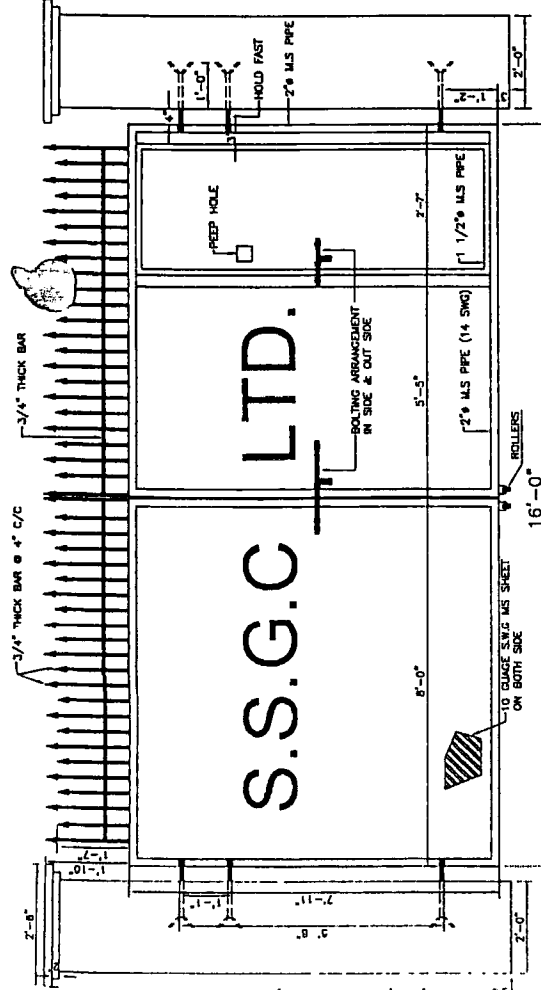
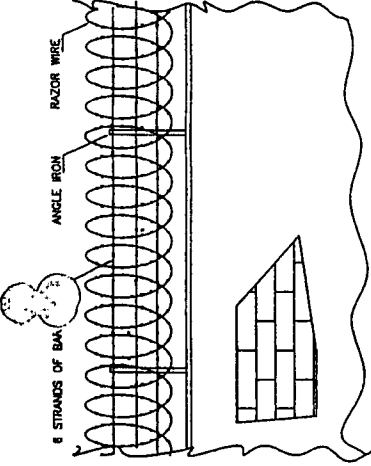

COMBINED FOOTING PLAN

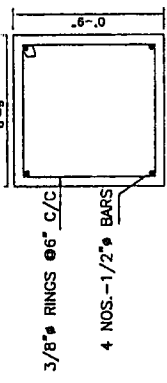

BOUNDARY WALL COLUMN

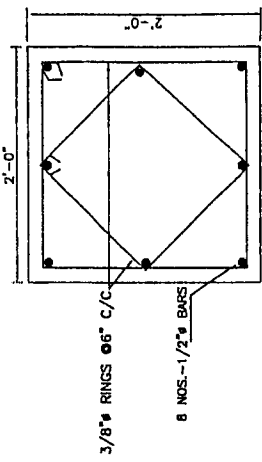

PLAN A-A GATE COLUMN

SECTION OF GATE COLUMN

SECTION OF COLUMN

SUI SOUTHERN GAS CO. LTD.
 TEB BBN GASBIM INDUSTRIAL PARK
 DETAIL OF BOUNDARY WALL
 DWG. NO: C59-BCIP-TYP-BWALL-0007

ISSUE NO.	DATE	DESCRIPTION
02	04-03-24	ISSUE FOR CONSTRUCTION
01	04-03-24	ISSUE FOR APPROVAL

DESIGN SECTION	CHKD BY	DATE
DESIGN SECTION	CHKD BY	DATE

SHEET NO.	1 OF 1
PLOT NO.	23.5
PROJECT CODE	C59
PLOT SCALE	1:500
PLOT AREA	23.5
PLOT NO.	2



Handwritten signature and initials.

Page 3 of 7

1. CONCRETE QUALITY TO BE 3000 PSI AT 28 DAYS.
2. CONCRETE COVER TO ALL BARS FROM WORK / SHALL BE 2 INCH MINIMUM/ OR OTHERWISE AS SHOWN IN THE DRAWINGS.
3. ALL STEEL BARS TO BE USED OF 60000 PSI YIELD STRENGTH.
4. CEMENT PLASTER TO BE USED FOR CONCRETE BELOW PLINTH LEVEL.
5. STEEL FORMWORK TO BE USED FOR FAIR SURFACE OF CONCRETE.
6. FOUNDATION ELEVATION SHALL BE CHECKED AT SITE ALONG WITH THE PIPELINE DRAWINGS.
7. EXCAVATION FOR FOUNDATION IS TO BE MADE TRUE TO DIMENSIONS FILLING OF EARTH TO MAINTAIN LEVEL/DEPTH IS NOT ALLOWED.

CONCRETE FOR ALL TYPE OF WORK SHALL BE MACHINE MIXED, VIBRATED WITH MECHANICAL VIBRATORS AND LAD PROPERLY. CONSTRUCTION SHALL BE IN ACCORDANCE WITH THE LOCATIONS INDICATED ON THE DRAWINGS.

MINIMUM PERIOD OF CURING FOR CONCRETE WORK SHALL BE 14 DAYS (FOURTEEN) DAYS. ALL EXPOSED SURFACES OF THE CONCRETE WORK SHALL BE TRUE AND SMOOTH FINISH BY USING SUITABLE FORM/SHUTTERING BLOCK MASONRY FROM PLINTH TO BE LAD IN 1:4 CEMENT SAND MORTAR.

ALL MASONRY WORK SHALL BE PROPERLY FINISHED BY USING SUITABLE FORM/SHUTTERING BLOCK MASONRY SURFACE CONTINUE-DUSLY WET.

INSIDE/OUT SIDE PLASTER BELOW FLOOR LEVEL, BE DONE IN 1:4 CEMENT MORTAR (S.F. CEMENT), ALL PLASTER AND POINTING WORK SHALL BE PROPERLY CURED WITH WATER FOR 7 DAYS. BARS CUT BY OPENING IN WALL TO BE PLACED IN DIAGONALS AROUND OPENING.

AUTHORISED FOR ISSUE		REVISIONS	
DATE	BY	NO.	DESCRIPTION
21-03-24		01	FLOOR LEVEL IS RAISED AS PER P&C REQUIRED

SUI SOUTHERN GAS CO. LTD.
 100% EXTERNAL FROM EXISTING FTCL EXCHANGE TO BHN QASMI PROJECT

DETAILS OF GUARD ROOM AT TBS BQIP

DWG NO: C59-TBS-BQIP-C8004
 DWG SCALE: SHEET SIZE: 11.5 X 17.5
 ISSUED NO: 1
 DATE: 21-03-24

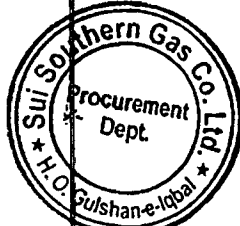
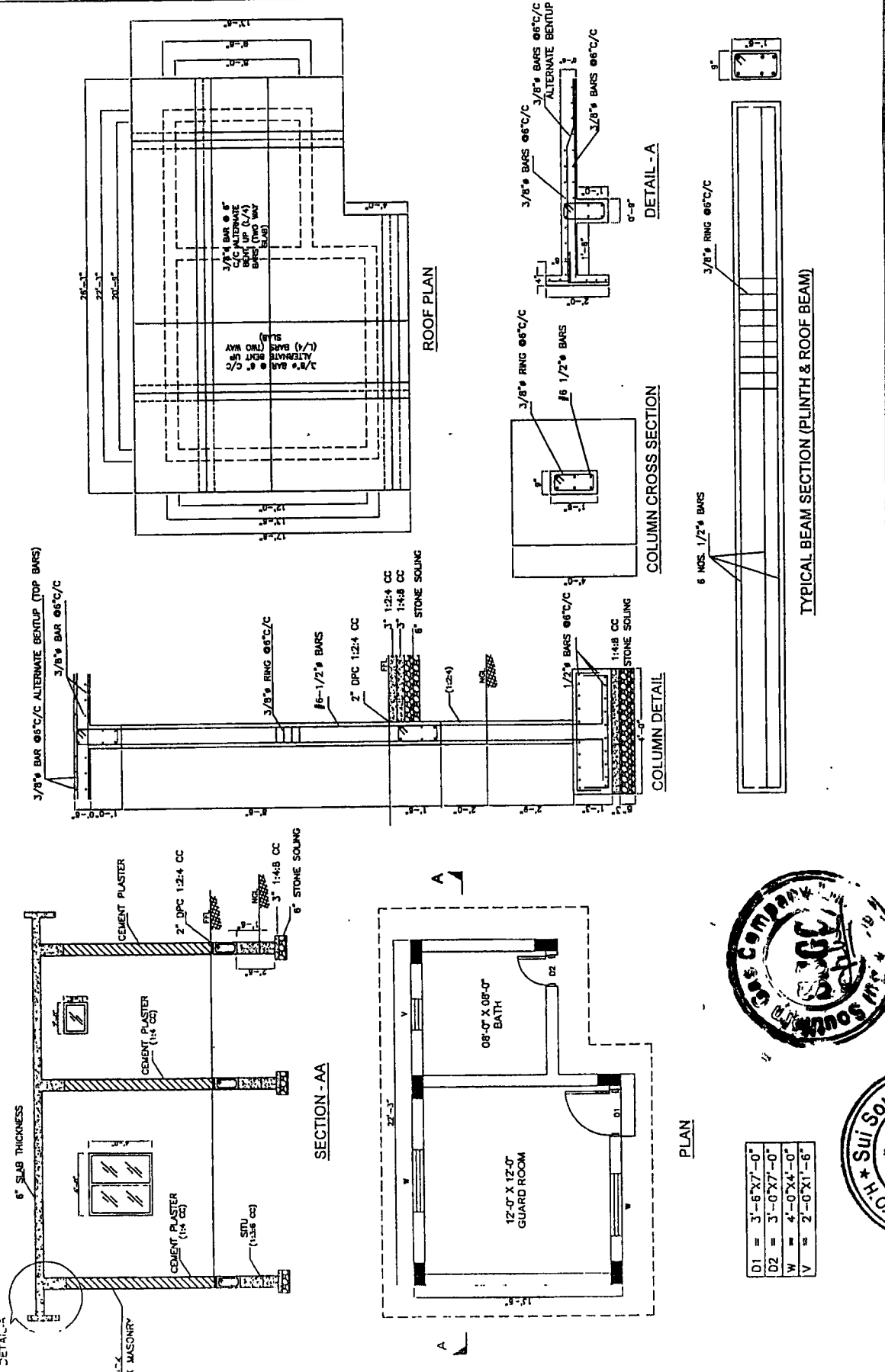

D1	=	3'-6" X 7'-0"
D2	=	3'-0" X 7'-0"
W	=	4'-0" X 4'-0"
V	=	2'-0" X 1'-6"

Handwritten signature: M. A. Hossain
Handwritten text: CC/Comp. POC.

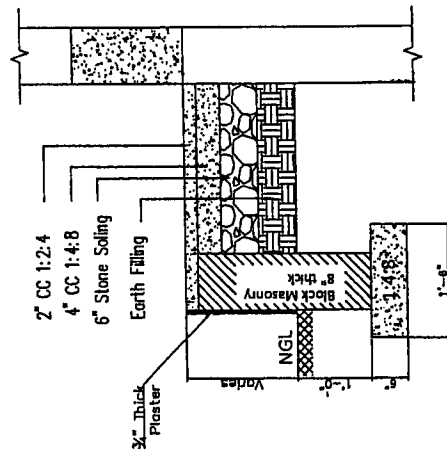
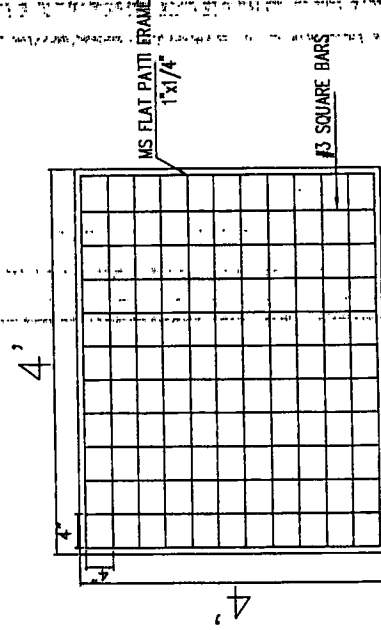
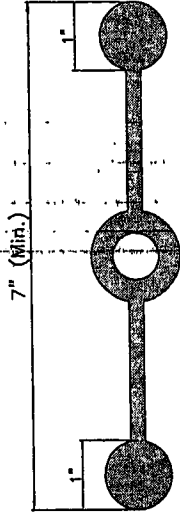
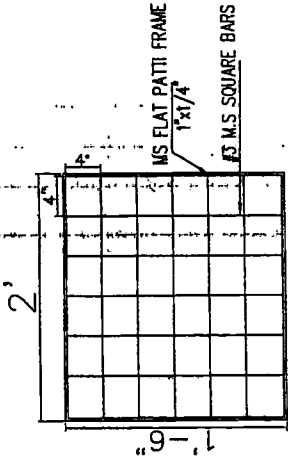
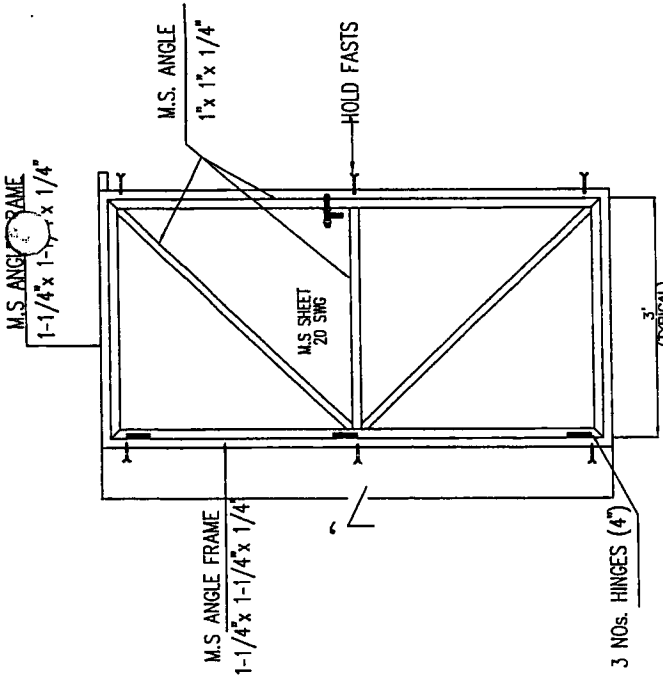

Handwritten signature and initials

SUI SOUTHERN GAS COMPANY LIMITED: PROJECTS & CONSTRUCTION DEPARTMENT TBS AT BIN QASIM INDUSTRIAL PARK, KARACHI	Prepared By:	SHAHHASSAN	Design:	MUHAMMAD TALIB (AE)	Issue No.	00
	Date:	02 May, 2024	DWG No.	0000-01	Sheet No.	1 / 1

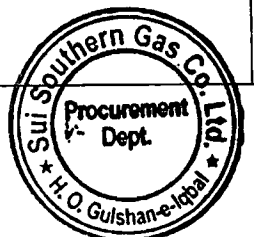

GENERAL NOTES

- CONCRETE QUANTITY TO BE QUOTED TO BE IN ACCORDANCE WITH THE DRAWINGS. CONCRETE COVER TO REINFORCEMENT SHALL BE 2" MINIMUM UNLESS OTHERWISE SPECIFIED.
- ALL STEEL REINFORCEMENT SHALL BE AS PER IS:1786.
- ALL STEEL BARS TO BE USED SHALL BE OF GRADE 45.
- REINFORCEMENT SHALL BE PLACED IN ACCORDANCE WITH THE DRAWINGS.
- CONCRETE SHALL BE PLACED IN LAYERS OF 150 MM TO 200 MM. CONCRETE BELOW FLOOR LEVEL SHALL BE PLACED IN LAYERS OF 150 MM TO 200 MM.
- STEEL REINFORCEMENT SHALL BE CHECKED AT SITE ALONG WITH THE PRELIMINARY DIMENSIONS.
- FOUNDATION DIMENSIONS SHALL BE CHECKED AT SITE ALONG WITH THE PRELIMINARY DIMENSIONS.
- CONCRETE FOR ALL TYPE OF WORK SHALL BE MACHINE MIXED VIBRATED WITH MECHANICAL COMPACTORS. THE MIXTURE SHALL BE PROVIDED AT LOCATIONS INDICATED ON THE DRAWINGS.
- MINIMUM PERIOD OF CURING FOR CONCRETE WORK SHALL BE 14 (FOURTEEN) DAYS.
- ALL EXPOSED SURFACES AND LINES OF THE CONSTRUCTION SHALL BE FINISHED BY USING SUITABLE FORMS/SHUTTERS.
- INSIDE/OUT SIDE PLASTER BELOW FLOOR LEVEL SHALL BE DONE IN 1:4 SAND MORTAR (S/R CEMENT) PROPERLY CURD WITH WATER FOR 7 DAYS.
- BARS CUT BY OPENING IN WALL TO BE PLACED IN DIAGONALS AROUND OPENING.

APPROVED FOR ISSUE

DATE OF APPROVAL: 27-02-24

REVISIONS

DESIGNER: SHRI K. S. SHARMA

DATE: 27-02-24

SECTION: SECTION-AA

SUI SOUTHERN GAS CO. LTD.

BIN GASIM INDUSTRIAL PARK

TYPICAL DETAIL OF UNDER GROUND WATER TANK

DWG NO: CGS9-BQTP-UGT-C8008

SCALE: 1/2" = 1'-0"

ISSUE NO: 1

DATE: 27-02-24

BY: S. S. SHARMA

CHECKED BY: S. S. SHARMA

APPROVED BY: S. S. SHARMA

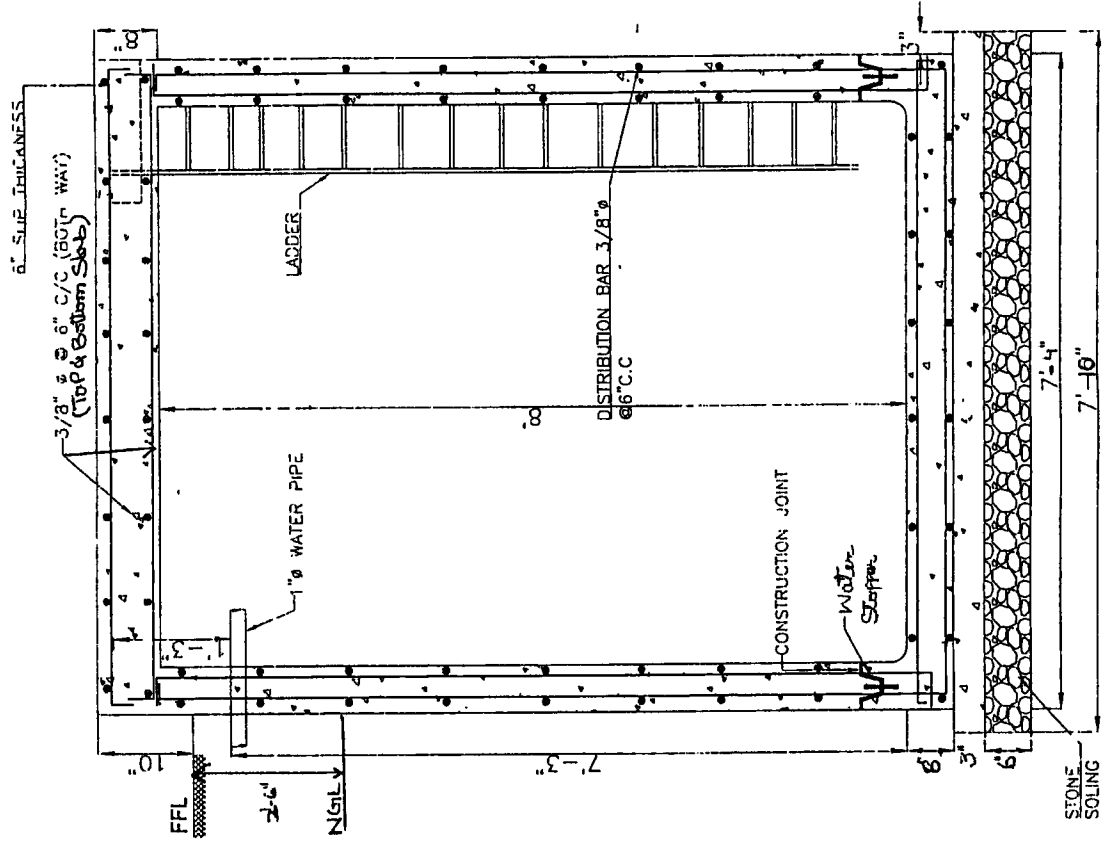

SECTION-AA

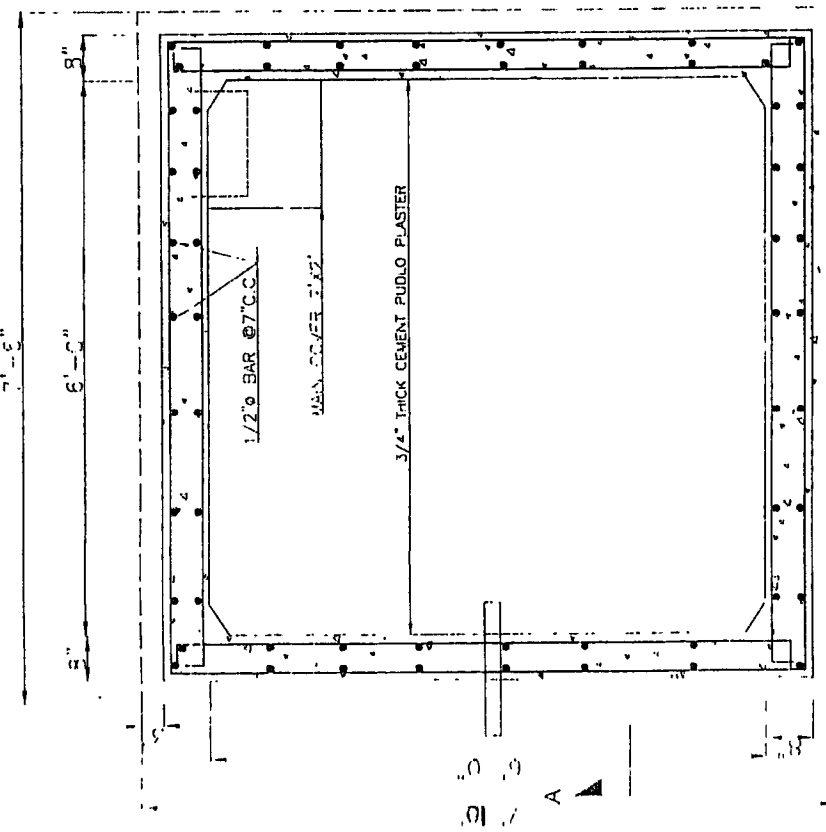

PLAN



**S. S. SHARMA*
DESIGNER